

CITY OF HOSCHTON  
CITY COUNCIL  
THURSDAY, JANUARY 11, 2024 AT 6:00PM  
HOSCHTON COMMUNITY CENTER  
65 CITY SQUARE, HOSCHTON



---

**WORK SESSION**  
**AGENDA**

---

CALL TO ORDER

AGENDA APPROVAL

REPORTS BY MAYOR, COUNCIL, AND STAFF

OLD BUSINESS

1. Resolution 24-01: Water Purchase Agreement with Barrow County
2. Resolution 24-02: Intergovernmental Agreement for Lease of 69 City Square between the City of Hoschton and the Hoschton Downtown Development Authority

NEW BUSINESS

1. **Final Plat for Creekside Village Towns:** UTR Hoschton, LLC, property owner, Premier Residential Builders Georgia, LLC, by Harold Trip, applicant, seeks final plat approval for 31 fee-simple townhouse lots on 3.03 acres (Map/Parcel 119/004N2) fronting on the south side of Eagles Bluff Way and including the dedication of Creekside Commons Drive (approximately 860 linear feet) Mixed Use (MU) zoning (Z-19-02) (V-23-05 and V-23-06)
2. Authorization to initiate amendments to the zoning ordinance, subdivision and land development ordinance, and the city's code of ordinances as necessary to establish a planning and zoning commission and assign various functions to the commission relative to zoning and subdivision applications.
3. Ordinance O-24-01: Narrow Strip Ordinance
4. 2024 Recommendation of Council Meeting Dates and Time
5. 2024 Recommendation of Downtown Development Authority Meeting Dates and Time
6. 2024 Proposed Historic Preservation Committee Meeting Dates and Time
7. 2024 Municipal Court Dates and Time

8. 2024 Recommendation to appoint new Downtown Development Authority Board Members
9. 2024 Recommendation of Council Committees from Mayor Martin
10. 2024 Recommendation of Mayor Pro-Tem
11. 2024 Recommendation of Ethics Board Members
12. Garland Contractors, Inc. estimate for construction of Public Works building
13. Consideration of Building Inspection Agreement

CITIZEN INPUT

EXECUTIVE SESSION (IF NEEDED)

ADJOURN

Monthly  
Departmental  
Reports

## DECEMBER 2023

- Met with SPLOST committee to request approval to help pay water/sewer debt and also to put last of the park and rec money towards ongoing park project. SPLOST 6 is now completed, and we have started the next program, which is SPLOST 7.
- We had the opportunity to take Mayor Brown & Councilmember Brown, along with newly elected members as well to tour the sewer plant.
- City Manager, City Clerk and Mayor had the opportunity to meet with all the other City Managers, City Clerks and Mayors in Jackson County. County Manager, Mr. Kevin Poe to discuss T-SPLOST (Transportation Special Purpose Local Option Sales Tax).
- Mayor Martin and myself met with Downtown Development Authority to discuss 2024 vision.
- DDA held a ribbon cutting for one of our newest businesses, Putters Golf Carts. We are happy to have them here!
- DCA (Department of Community Affairs) Met with Mayor Martin and myself. Gave many great ideas to start off the 2024 year. We look forward to working with our district rep on future projects.
- Tiffany, Finance Director and myself participated in a grant class to learn about more grant opportunities for the city.
- Mayor Council and Councilmember Sterling gathered Christmas gifts from all the councilmembers and blessed several families in our community.
- Question & Answers with Commissioner Chad Bingham was informative for our citizens. We look forward to January 25<sup>th</sup> at 6:30pm with Mr. Mark Kooyman, Mark Kooyman- Discovery Chief of EXPERIENCE.

**Best Regards,  
Jennifer Harrison  
City Manager**

# Building Department Activity Report-December 2023

## A. Building department activity

### a. Permits Issued

- i. August - 22 Res. Building / 21 Miscellaneous
- ii. September - 52 Res. Building / 9 Miscellaneous
- iii. October - 37 Res. Building / 2 Miscellaneous
- iv. November - 12 Res. Building / 9 Miscellaneous
- v. December - 18 Res. Building / 5 Miscellaneous
- vi. 2023 YTD – 495 Res. Building / 108 Misc.

### b. Inspection Activity

#### i. August Total Inspections

1. Building Inspections – 286
2. Water Meter Install Inspections – 26

### c. Commercial Permit Activity - YTD Permits - 11

1. Publix active construction
2. Publix rental units (8 unit) Active
3. Hoschton Storage



## December 2023 Monthly Report

### Water

- Daily water route check of connections, water tank and random sample sites
- Daily checks and operations of both city wells
- Daily water sampling
- Weekly well cleanings
- Monthly Meter high usage and non-read meter reading
- Pulled monthly Reporting EPD Samples
- Pulled monthly Bacteriological samples throughout water system
- Replenished Chemicals at both Wells
- Daily utility locates, 237 water/sewer locates for the month of December
- Recorded all daily, weekly, and monthly Data
- Completed and Submitted Monthly Water Reports to EPD
- Installed 38 new Water Meters
- Repaired 13 customer Water Meters
- Repaired 4 water leaks in water system
- Installed Water Tap for a newly constructed house in Brighton Park
- Had a meeting with Jackson County about future water Purchase
- Continued working on Water Purchase Agreement with Barrow County

### Wastewater

- Daily Plant check of equipment and processes
- Daily sampling and testing of plant Effluent
- Daily Instrument calibrations
- Daily lab equipment temperature checks

- Weekly process control lab work
- Weekly Automatic samplers turned on and checked
- Pulled Weekly permit samples
- Performed weekly permit Lab testing
- Recorded all daily, weekly, and monthly Data
- Performed Maintenance on Dewatering Belt Press
- Performed Weekly and monthly Maintenance on Clarifiers
- Performed Weekly Sewer pump station and generator check
- Ran Belt Press weekly to remove excess solids in Plant
- Weekly Washdown and cleaning of tanks, troughs, and filter
- Daily utility locates, 237 water/sewer locates for the month of December
- Completed and Submitted Monthly Wastewater Report (DMR) to EPD
- Performed a Plant Tour for newly elected officials.
- Zeta Solutions came out to the Wastewater Treatment plant and started a Phosphorus Removal Trial with a chemical called PAC (Poly-Aluminum Chloride). This trial was needed as a part of the Treatment plant Expansion.
- Continued to monitor the phosphorus levels in the plant for 2 weeks
- Installed Sewer Tap for a newly constructed house in Brighton Park

## **Police Department Report 01/03/2024**

1. **Reports and Citations**- The Police Department generated right at 2700 incident numbers in 2023 and wrote 46 citations in the month of December.
2. **Court**- We will have court again on February 15th at City Hall.
3. **Training**- I attended Taser instructor in Albany Ga. Once I completed the course I came back and taught a Taser class at the police department.



# OLD BUSINESS

## ITEM #1

Resolution 24-01: Water Purchase  
Agreement with Barrow County

CITY OF HOSCHTON  
STATE OF GEORGIA

**Resolution 2024-01**

**A RESOLUTION OF THE CITY COUNCIL OF  
THE CITY OF HOSCHTON, GEORGIA  
AUTHORIZING THE APPROVAL OF A WATER PURCHASE AGREEMENT  
WITH THE BARROW COUNTY BOARD OF COMMISSIONERS**

**WHEREAS**, the CITY OF HOSCHTON is organized and established under the laws of Georgia for the purpose of serving water users, BARROW COUNTY is authorized to provide such service, and the Parties are authorized under Article IX, Section III, Paragraph I of the Georgia Constitution to contract for the provision of water service; and

**WHEREAS**, the Parties desire to enter into an Agreement for the sale and purchase of potable water as set forth in the terms and conditions outlined in the proposed water purchase agreement; and

**WHEREAS**, the City of Hoschton is desirous of a reliable supplemental supply of potable water, and

**WHEREAS**, Barrow County has sufficient surplus water supply to provide a long term potable water supply for the City of Hoschton's growing water demand, and

**WHEREAS**, the City of Hoschton has existing and planned infrastructure sufficient to receive and deliver a potable water supply source from Barrow County, and

**WHEREAS**, a proposed water purchase agreement with Barrow County has been developed with reasonable terms and conditions.

**NOW THEREFORE** be it resolved by the City Council of the City of Hoschton to authorize the approval of the proposed agreement for water purchase with the Barrow County Board of Commissioners.

**BE IT FURTHER RESOLVED** to authorize the Honorable Debbie Martin, Mayor, and City Manager/Clerk, Jennifer Kidd-Harrison to execute the water purchase agreement on behalf of the City.

**THIS RESOLUTION READ AND PASSED BY A QUORUM OF THE CITY COUNCIL OF THE CITY OF HOSCHTON, GEORGIA, ON THIS 15TH DAY OF JANUARY, 2024 AND HAS NOT BEEN RESCINDED IN ANY WAY.**

By: \_\_\_\_\_  
Ms. Debbie Martin, Mayor

By: \_\_\_\_\_  
City Clerk

(Seal)

**STATE OF GEORGIA  
COUNTY OF BARROW**

**WATER PURCHASE CONTRACT**

This Agreement is made and entered into effective this \_\_\_\_\_ day of \_\_\_\_\_, 2024 (the “Intergovernmental Agreement Effective Date”), by and between the **BARROW COUNTY**, a political subdivision of the State of Georgia (herein sometimes called “**BARROW COUNTY**”), and the **CITY OF HOSCHTON**, a municipal corporation of the State of Georgia (herein sometimes called “**CITY OF HOSCHTON**”). **BARROW COUNTY** and the **CITY OF HOSCHTON** may be referred to collectively herein as the “Parties” or individually as a “Party.”

**Witnesseth:**

**WHEREAS**, the **CITY OF HOSCHTON** is organized and established under the laws of Georgia for the purpose of serving water users, **BARROW COUNTY** is authorized to provide such service, and the Parties are authorized under Article IX, Section III, Paragraph I of the Georgia Constitution to contract for the provision of water service;

**WHEREAS**, the Parties hereto desire to enter into an Agreement for the sale and purchase of potable water and to set forth the terms and conditions for the sale thereof;

**WHEREAS**, **BARROW COUNTY** will be the wholesale seller of water; and

**WHEREAS**, **CITY OF HOSCHTON** will be the wholesale purchaser of water.

**NOW, THEREFORE**, for and in consideration of the mutual promises contained herein, and for other good and valuable consideration, the receipt and sufficiency of which is hereby acknowledged, the Parties hereto intend to be legally bound, and do agree as follows:

1. **Allocation.** The above recitals are made a part of this Agreement. **BARROW COUNTY** agrees to make available to the **CITY OF HOSCHTON** at the hereinafter referred to point of delivery, during the term of this Agreement or any renewal or extension thereof, potable water meeting applicable purity standards of the Georgia Department of Health and the Georgia Department of Natural Resources, Environmental Protection Division in such quantity and at such prices as specified hereinafter in this Agreement.
2. **Quantity of Water.** Except as qualified below, commencing on the Water Utility Provision Effective Date (defined below) of this Agreement and continuing for a period of not more than ten (10) years, and as this Agreement may thereafter be extended, **BARROW COUNTY** agrees to make available to the **CITY OF HOSCHTON** at the designated point of delivery hereinafter specified, potable water in a minimum quantity of 300,000 GPD (gallons per day) or a minimum quantity of 9,000,000 gallons per month. Notwithstanding anything herein to the contrary, **BARROW COUNTY** shall

have no requirement to provide any amount of water at any rate that may jeopardize BARROW COUNTY's water system. Additionally, BARROW COUNTY's obligation to provide water hereunder at the minimum rate stated above is contingent on the completion of necessary water system facility upgrades and modifications, more particularly depicted on the attached Exhibit A and described as follows:

- a. To accommodate CITY OF HOSCHTON's connection to BARROW COUNTY's water system, BARROW COUNTY will install approximately 4,500 LF of 12" diameter water main along Covered Bridge Road from its existing water distribution system at the intersection of Covered Bridge Road and SR 211. BARROW COUNTY will also install control valve/meter vaults at the east end of the water main extension, west of the Mulberry River. CITY OF HOSCHTON shall participate in the total cost of the water line infrastructure on the Barrow County side by 50% to allow connection to water system. The current estimated cost for this infrastructure is \$1,250,000.
  - b. CITY OF HOSCHTON will be responsible for connecting to the new water main on the downstream side (east side) of the vaults, to include upgrading the vault and metering station, as necessary.
  - c. The facility improvements described in subsections a. and b. above are necessary to allow BARROW COUNTY's supply of up to 300,000 GPD of water to CITY OF HOSCHTON. This work is anticipated to be completed by January 1, 2026.
  - d. In addition to the above-described improvements, upon CITY OF HOSCHTON's further installation of approximately 7,300 LF of 12" diameter water main along Peachtree Road from the Covered Bridge Road connection point, such infrastructure is anticipated to accommodate up to a maximum of 2,000,000 GPD of water supply from BARROW COUNTY to CITY OF HOSCHTON. Upon completion by the CITY OF HOSCHTON of the installation of improvements set forth in this subsection, BARROW COUNTY agrees to increase the provision of water up to a maximum amount of 2,000,000 GPD.
3. **Points of Delivery and Pressure.** At no time shall the residual water pressure on the BARROW COUNTY side of the meter be lower than 20 PSI (pounds per square inch) due to the combined operations of BARROW COUNTY and CITY OF HOSCHTON. The point of delivery is located at the connection point of the CITY OF HOSCHTON water system and BARROW COUNTY line. As described above and as depicted on the attached Exhibit A, the connection point located at Covered Bridge Road and Peachtree Road will be improved to a 12" water main by BARROW COUNTY and shall be connected at the point of delivery by CITY OF HOSCHTON to their system

and available for use at this location no later than January 1, 2026 (the “Water Utility Provision Effective Date”).

4. **Supplemental Supply of Water.** The CITY OF HOSCHTON may purchase from BARROW COUNTY additional potable water in excess of the daily firm quantity established in paragraph 2 of this Agreement based on the availability of such additional water. Conditioned on the completion of all anticipated facility improvements referenced in paragraph 2 above, BARROW COUNTY agrees to said excess water purchases of 2,000,000 GPD, and CITY OF HOSCHTON shall pay for such excess water at the rates subsequently set forth in this Agreement.
5. **Billing Procedure.** BARROW COUNTY will furnish the CITY OF HOSCHTON at its address stated in paragraph 13 below, a monthly itemized invoice of the amount of water provided from BARROW COUNTY to the CITY OF HOSCHTON and the amount owed to BARROW COUNTY from the CITY OF HOSCHTON under this Agreement for such water. The standard billing procedures of BARROW COUNTY shall apply, which includes billing the CITY OF HOSCHTON on a monthly basis for water purchased, and the CITY OF HOSCHTON shall fully satisfy such invoices in full within thirty (30) days of BARROW COUNTY mailing of same to the CITY OF HOSCHTON.
6. **Metering Equipment.** The parties agree that BARROW COUNTY will provide sufficient metering equipment needed under this Agreement near the end of the existing Barrow County line in Barrow County, Georgia. A meter registering not more than two percent (2%) above or below BARROW COUNTY’s test results shall be deemed to be accurate. The previous reading of any meter disclosed by test to be inaccurate shall be corrected for the three (3) months previous to such test in accordance with the percentage of inaccuracy found by such test. If any meter fails to register for any period, the amount of water furnished during such a period shall be deemed the average amount of water delivered during the three (3) month period immediately prior to the failure, unless BARROW COUNTY and CITY OF HOSCHTON at a reasonable time shall have access to the meter for purpose of reading same. The metering equipment shall be tested and calibrated within ninety (90) days of the Intergovernmental Agreement Effective Date, and annually each year thereafter.
7. **Term of Agreement.** In compliance with O.C.G.A. 36-1-26 (1), this Water Service Agreement will be for no more than ten (10) years and shall be in full force and effect for a period beginning on the Water Utility Provision Effective Date and ending on **December 31, 2035.**

This Agreement may be renewed upon approval by both CITY OF HOSCHTON and BARROW COUNTY for up to two (2) additional ten (10) year periods.

**Failure to Deliver.** BARROW COUNTY will at all times, operate and maintain its water system in a reasonable and professional manner, consistent with industry standards, and will take such actions as may be necessary to furnish the CITY OF HOSCHTON with the minimum quantities of water required by this Agreement. Temporary or partial failure to deliver water shall be remedied by BARROW COUNTY with all possible dispatch. In the event of an extended shortage of water beyond the control of BARROW COUNTY, or the supply of water available to BARROW COUNTY is otherwise diminished over an extended period of time, the supply of water to CITY OF HOSCHTON's customers shall be reduced or diminished in the same ration or portion as the supply to BARROW COUNTY customers is reduced or diminished.

**8. Price of Water.** The purchase price of water supplied under this Agreement will be determined by BARROW COUNTY subject to availability of water from BARROW COUNTY and provision of wholesale water to BARROW COUNTY'S wholesale water customers with minimum purchase obligations. Until such rate may be modified as provided herein, the price of water shall be set at **\$ 3.40** per 1,000 gallons. Except as qualified below, the CITY OF HOSCHTON shall not pay less than a monthly minimum charge which shall be equivalent to the cost of purchasing 300,000 gallons of water per day at the set rate for K/gal per 30-day period (or, as determined on a minimum monthly basis, 9,000,000 gallons per month). This monthly charge shall be paid whether or not the CITY OF HOSCHTON purchases an average of 300,000 GPD of potable water. During this agreement, any month after the CITY OF HOSCHTON consistently purchases the monthly minimum of 1,000,000 GPD (gallons per day) or as determined on a monthly basis minimum 30,000,000 MG (million gallons per month), the price of water shall be set at **\$ 3.10** per 1,000 gallons. In April of each year of the Term, BARROW COUNTY will review the rate and increase such rate as needed in response to changes in the uniform rate from the Upper Oconee Basin Water Authority ("UOBWA") and BARROW COUNTY system operational cost. BARROW COUNTY will review the rate and increase such rate as needed in response to changes in the water system operating costs. Rate adjustments for operational cost will not exceed the CPI rate on an annual basis. Rate adjustments based on such reviews will be applicable beginning on the following first day of July. As stated in paragraph 2 above, until certain water infrastructure upgrades and modifications are made to BARROW COUNTY's water distribution system at the Cover Bridge Road and Peachtree Road Line, BARROW COUNTY can only provide an average of 300,000 GPD or, as determined on a minimum monthly basis, 9,000,000 gallons per month; therefore, during such time, the CITY OF HOSCHTON shall only be required to pay a monthly minimum charge which is equal to the cost of purchasing 300,000 gallons of water per day at the set rate for K/gal per 30-day period. However, the CITY OF HOSCHTON shall be required to pay for all water pulled above the minimum on a per 1,000-gallon basis at the rate stated above. Once BARROW COUNTY determines that system improvements can accommodate a larger volume GPD average, BARROW COUNTY will notify the CITY OF HOSCHTON accordingly.

If BARROW COUNTY is unable to provide the required minimum GPD to the CITY OF HOSCHTON due to a system failure or inability to produce the required GPD of the Take or Pay

Clause, then, in that event, the CITY OF HOSCHTON shall only be responsible to pay for the amount of actual GPD supplied.

If at any time during the term of this Agreement, the BARROW COUNTY's cost for treated water from the Upper Oconee Basin Water Authority or the cost to deliver wholesale water change, the price will be adjusted by the required percentage rate to reflect such change after 30 days' written notice from BARROW COUNTY to the CITY OF HOSCHTON of such change.

**9. Additional Consideration.** CITY OF HOSCHTON and BARROW COUNTY will enter into a separate sewer agreement setting forth details as to the understanding between the parties, CITY OF HOSCHTON shall make available to BARROW by December 1, 2028, the collection system infrastructure with a sewer flowmeter a minimum of 250,000 GPD of wastewater treatment capacity as needed will be available to BARROW. BARROW will provide the collection system infrastructure necessary to connect to HOSCHTON collection system (at a general site identified by the Parties). BARROW shall pay HOSCHTON standard Tap/Capacity connection fees. Hoschton will establish an annual wholesale rate based on audited treatment costs on a per thousand-gallon basis, less depreciation and less debt service, plus (5%) five percent. An annual rate will be established in March of each year based on the previous audited financial statement and wastewater treatment facility operating records.

**10. Payment.** If the CITY OF HOSCHTON fails to fully satisfy any invoice for any water delivered to the CITY OF HOSCHTON by BARROW COUNTY within the period herein provided, then BARROW COUNTY shall have the right to cease delivering water to the CITY OF HOSCHTON at any time it elects to do so, provided BARROW COUNTY first provides at least fifteen (15) days' notice of intent to do so to the CITY OF HOSCHTON and the CITY OF HOSCHTON fails to cure all past due amounts, including a penalty of two percent (2%) per month of all amounts remaining past due, within such fifteen (15) day period.

The obligation of the CITY OF HOSCHTON to pay for water delivered under this agreement shall never be construed to be a debt of the CITY OF HOSCHTON requiring it to levy and collect a tax to discharge the same but shall be an operating charge of its water system ranking equally to charges for salaries, wages and other operating expense of such system. The CITY OF HOSCHTON shall, at all times, establish, maintain, prescribe and collect fees, tolls and charges for water facilities furnished to its customers sufficient to provide funds for the payment of all obligations of the CITY OF HOSCHTON under this agreement.

**11. Rules and Regulations.** BARROW COUNTY and the CITY OF HOSCHTON will collaborate and obtain such permits, certificates and the like, or as may be required to comply with State law. The CITY OF HOSCHTON agrees to comply with all rules and regulations, which BARROW COUNTY has now or may in the future, impose on its water customers. These rules and regulations may include, but shall not be limited to, any imposed water reduction requirements or such emergency measures as bans on water sprinkling, hydrant flushing, car washing and similar issues. Any fees or penalties imposed on BARROW COUNTY for violation of any required water reduction or restriction or any emergency measures that are caused by or result from the CITY OF HOSCHTON's water use hereunder shall be passed through to and shall be paid by the CITY OF HOSCHTON.

**12. Notice.** All notices, requests, demands and other communications required or permitted to be given hereunder shall be in writing by US certified mail, return receipt requested, and shall be addressed and delivered to each Party at the address set forth below. By giving prior written notice thereof, either Party may from time to time and at any time change its address for notices hereunder.

Barrow County Board of Commissioners  
30 North Broad Street  
Winder, Georgia 30680

City of Hoschton  
61 City Square  
Hoschton, Georgia 30548

**13. Georgia Law.** It is the intention of the Parties that the laws of the State of Georgia shall govern the validity of this Agreement, the construction of its terms and the interpretation of the rights or duties of the parties.

**14. Cooperation.** On and after the date of this Agreement, either Party shall at the request of the other, make, execute and deliver or obtain and deliver all instruments and documents and shall do or cause to be done all such other things which either party may reasonably require to effectuate the provisions and intention of this Agreement.

**15. Power.** The Parties signing this Agreement hereby state that they have the power to do so on behalf of the entity for which they are signing.

**16 Effective.** This Agreement shall be effective upon the Parties hereto and their assigns, and successors in office.



**17. Cumulative.** Except as expressly limited by the terms of this Agreement, all rights, powers and privileges conferred hereunder shall be cumulative and not restrictive of those provided at law or inequity.

**18. Force Majeure.** In case by reason of force majeure, any Party hereto shall be rendered unable wholly, or in part, to carry out its obligations under this Agreement then if such shall give notice and full particulars of such force majeure in writing to the other Party within a reasonable time after occurrence of the event or cause relied on, the obligation of the Party giving such notice, so far as it is affected by such force majeure, shall be suspended during the continuance of the inability then claimed, but for no longer period. Such Party shall endeavor to remove or overcome such inability with all reasonable dispatch. The term "force majeure" as employed herein, shall mean act(s) of God, strikes, lockout(s) or other industrial disturbance(s), act(s) of a public enemy, order(s) of any kind of the Government of the United States, of the State of Georgia or any civil or military authority, insurrections, riots, epidemics, landslide, lightening, earthquakes, fires, hurricanes, storms, floods, washouts, droughts, arrests, restraint of Government and people, civil disturbances, explosions, breakage or accident(s) to machine or pipelines, or any other cause(s) outside the parties control which prevent performance under this agreement. Should interpretations and or lowering of pressure occur, the CITY OF HOSCHTON shall be foreclosed from any action against Barrow County and shall hold BARROW COUNTY harmless from any fees including attorney's fees and court costs incurred from any action by one or more of the CITY OF HOSCHTON customers.

**19. Supersede.** This Agreement shall supersede and replace all letters, memoranda, or other letters or documents signed by the Parties hereto with respect to the sale of potable water by BARROW COUNTY to the CITY OF HOSCHTON.

**20. Water Supply.** The CITY OF HOSCHTON is aware BARROW COUNTY has limited control over any source of water, therefore if for any reason the BARROW COUNTY does not receive the expected amount of water from Bear Creek Treatment Facility, BARROW COUNTY may reduce the amount of water to be furnished to the CITY OF HOSCHTON under this agreement.

In the event of such a reduction, or any reduction due to force majeure, BARROW COUNTY shall act in good faith and not unduly reduce the amount of water furnished under this agreement to CITY OF HOSCHTON.

(remainder of this page intentionally left blank)

(signature page follows)

**IN WITNESS WHEREOF**, the undersigned have hereunto set their hands and seals effective as of the date first above written.

**BARROW COUNTY, GEORGIA**, by and through its Board of Commissioners

By: \_\_\_\_\_  
Pat Graham, Chairman

Attest: \_\_\_\_\_  
County Clerk

(Affix County Seal)

**CITY OF HOSCHTON, GEORGIA**, by and through its Mayor and City Council

By: \_\_\_\_\_  
Debbie Martin, Mayor

Attest: \_\_\_\_\_  
Jennifer Kidd-Harison, City Manager and City Clerk

(Affix City Seal)

APPROVED AS TO FORM

\_\_\_\_\_  
Abbott S. Hayes, Jr., City Attorney

# OLD BUSINESS

## ITEM #2

Resolution 24-02: Intergovernmental  
Agreement with DDA for lease of  
69 City Square

**RESOLUTION 2024-02**

**Approval of Intergovernmental Agreement with the Hoschton Downtown Development Authority Regarding Property Located at 69 City Square Located in the Downtown Development Area of the City of Hoschton**

**WHEREAS**, the revitalization and redevelopment of the central business district of the City of Hoschton ("City") develops and promotes for the public good and general welfare trade, commerce, industry, and employment opportunities and promotes the general welfare of the City by creating a climate favorable to the location of new industry, trade, and commerce and the development of existing industry, trade, and commerce within the City; and

**WHEREAS**, it is in the public interest and vital to the public welfare of the citizens of the City to revitalize and redevelop the central business district of the City; and

**WHEREAS**, the City desires to convey the City's interest in marketing and leasing real property to the Hoschton Downtown Development Authority ("Authority"), such that the Authority may market and lease real property in furtherance of the Authority's mission and purpose.

**NOW, THEREFORE, BE IT RESOLVED THAT** the governing body for the City does hereby approve and adopt the Intergovernmental Agreement with the Authority attached hereto and does hereby authorize the Mayor, City Manager, and City Attorney to execute the Intergovernmental Agreement attached hereto, as well as such other documents and agreements that may be necessary to effectuate the provisions of the Intergovernmental Agreement.

**Adopted this \_\_\_\_ day of \_\_\_\_\_, 2024.**

---

**Debbie Martin, Mayor**

This is to certify that I am City Clerk of the City of Hoschton. As such, I keep its official records, including its minutes. In that capacity, my signature below certifies this resolution was adopted as stated and will be recorded in the official minutes.

**ATTEST:**

---

**City Clerk**

4892-1454-0698, v. 2

**INTERGOVERNMENTAL AGREEMENT BY AND BETWEEN  
CITY OF HOSCHTON, GEORGIA AND HOSCHTON DOWNTOWN DEVELOPMENT  
AUTHORITY REGARDING PROPERTY LOCATED IN THE DOWNTOWN  
DEVELOPMENT AREA OF THE CITY OF HOSCHTON**

This Agreement is made and entered into as of the \_\_\_\_ day of January, 2024, by and between the City of Hoschton, Georgia, hereinafter called "Hoschton" and the Hoschton Downtown Development Authority (hereinafter called "the Authority") for the purpose of conveyance of Hoschton's interest in leasing real property to the Authority, such that the Authority may lease real property in furtherance of the Authority's mission and purpose.

**WHEREAS**, Hoschton owns real property upon which the "Premises," as defined in the Retail Lease Agreement attached hereto as Exhibit "1" (hereinafter called "the Lease"); and

**WHEREAS**, Hoschton put out a request for proposals relating to the leasing of the Premises, to which "Tenant," as defined in the Lease responded; and

**WHEREAS**, the Premises is located in the Downtown Development Area of Hoschton; and

**WHEREAS**, pursuant to O.C.G.A. § 36-42-2, the purpose of the Authority is to revitalize and redevelop the Downtown Development Area of Hoschton, so as to develop and promote for the public good and general welfare trade, commerce, industry, and employment opportunities and promote the general welfare of Hoschton and surrounding communities; and

**WHEREAS**, pursuant to Section 6.33 of the Hoschton Charter, Article IX, Section III, Par. I of the Georgia Constitution, and O.C.G.A. § 36-42-8, Hoschton and the Authority have the power to enter into this Intergovernmental Agreement for the purpose of Hoschton granting the Authority the power to lease the Premises to fulfill the purpose of the Authority as set forth herein; and

**WHEREAS**, Hoschton and the Authority desire to enter into an agreement to provide for the conveyance of such rights to the Premises to the Authority to enable the Authority to lease the Premises to fulfill the purpose of the Authority as set forth herein.

**NOW THEREFORE**, Hoschton and the Authority agree to the following:

- A. Hoschton shall execute such documents as are necessary to convey Hoschton's rights to the Authority to lease the Premises to Tenant, in substantially the same form and on the same terms as set forth in the Lease.
- B. The Authority shall work diligently to lease the Premises in substantially the same form and on the same terms as set forth in the Lease to revitalize and redevelop the Downtown Development Area of Hoschton, so as to develop and promote for the public good and general welfare trade, commerce, industry, and employment opportunities and promote the general welfare of Hoschton and surrounding communities.
- C. Upon the leasing of the Premises, the net proceeds of rental income, after deduction of reasonable and customary costs associated with the leasing of the Premises, shall be paid to Hoschton.

- D. The power of the Authority to lease the Premises shall terminate either upon the termination of a lease in in substantially the same form and on the same terms as set forth in the Lease or within 60 days of the date of this Agreement without a lease being executed by the Authority and Tenant in in substantially the same form and on the same terms as set forth in the Lease, such that the Authority shall not have the power to lease the Premises thereafter unless extensions are negotiated and agreed to between Hoschton and the Authority.
- E. The Authority agrees to hypothecate its interest in the Premises to any lender as collateral for any loans related to the Premises.
- F. All notices under this Agreement shall be in writing and shall be deemed to have been given by delivering it to person or by certified mail:

As to the Authority:

Hoschton Downton Development Authority  
Attn: Chairperson  
61 City Square  
Hoschton, GA 30548

As to Hoschton

City of Hoschton  
Attn: City Manager  
61 City Square  
Hoschton, GA 30548

- G. The failure of any party to exercise any right given hereunder or to insist upon strict compliance with any term, condition or covenant specified herein shall not constitute a waiver of such party's right to exercise such right or to demand strict compliance with any such term, condition, or covenant under this Agreement.
- H. This Agreement contains the sole and entire agreement of the parties with respect to the subject matter contemplated hereunder and no representation, inducement, promise or agreement, parole or written, between the parties and not incorporated herein shall be of any force of effect. Any amendment to this Agreement shall be in writing and executed by the parties.
- I. This Agreement may not be assigned or transferred by either party without the written consent of the other party. The provisions of this Agreement shall inure to the benefit or and be binding upon the parties hereto and the respective success and assigns.
- J. Time is of the essence with respect to this Agreement.
- K. This Agreement and all amendments hereto shall be governed and construed under the laws of the State of Georgia.

- L. If any term, covenant or condition of this Agreement or the application thereof to any person or circumstance shall, to any extent, be invalid or unenforceable, such provision, or the application of such term, covenant or condition to persons or circumstances other than those as to which it is held invalid or unenforceable, shall be deemed severable, and the remainder hereof shall not be affected thereby, and each term, covenant, or condition of this Agreement shall be valid and be enforced to the fullest extent permitted by law.
  
- M. This Agreement may be executed in several counterparts, each of which shall constitute an original and all of which together shall constitute one and the same instrument. The Mayor, Clerk, City Manager, and City Attorney of Hoschton are hereby authorized to sign such documents as are necessary to effectuate the provisions of this Agreement. The Chairperson and Secretary of the Authority are hereby authorized to sign such documents as are necessary to effectuate the provisions of this Agreement.

IN WITNESS THEREOF, the parties have set their hand and seal as of the day and year first above written.

**HOSCHTON DOWNTOWN DEVELOPMENT AUTHORITY**

By: \_\_\_\_\_  
Chairperson

ATTEST: \_\_\_\_\_  
Secretary

**CITY OF HOSCHTON**

By: \_\_\_\_\_  
Debbie Martin, Mayor

ATTEST: \_\_\_\_\_  
City Clerk

APPROVED AS TO FORM

\_\_\_\_\_  
Abbott S. Hayes, Jr., City Attorney  
4874-7195-6885, v. 4

**RETAIL LEASE AGREEMENT**

**between**

**HOSCHTON DOWNTOWN DEVELOPMENT AUTHORITY  
("Landlord")**

**and**

**ATLANTA DEVELOPMENT COMPANY, LLC  
("Tenant")**

**Hoshton, Georgia**



**RETAIL LEASE AGREEMENT**

THIS RETAIL LEASE AGREEMENT (this "Lease") is made as of the \_\_\_\_ day of January 2023, by and between **HOSCHTON DOWNTOWN DEVELOPMENT AUTHORITY ("Landlord")** and **ATLANTA DEVELOPMENT COMPANY, LLC ("Tenant")**.

For and in consideration of the sum of Ten and No/100 Dollars (\$10.00) and other valuable considerations, including the mutual covenants and agreements of the parties set forth herein, Landlord leases to Tenant and Tenant leases from Landlord the premises described herein for the Term and subject to the terms and conditions set forth herein.

**Article 1.**  
**Introductory Provisions**

1.1. Fundamental Lease Provisions. Certain fundamental provisions are presented in this Section in summary form to facilitate convenient reference by the parties hereto:

- |     |                                 |  |
|-----|---------------------------------|--|
| (a) | Term                            | Five Years plus two (2) options to extend the term by five (5) years each (Article 3)                          |
| (b) | Interior Space                  | 2440 square feet, as shown in Exhibit A.   |
| (c) | Rent                            | Rent schedule set forth in Exhibit B   |
| (d) | Commencement Date               | The " <b>Commencement Date</b> " as used in this Lease shall be the ____ day of _____, 202__.                  |
| (e) | Permitted Use                   | The Premises shall be occupied and used solely for the purpose of a restaurant.                                |
| (f) | Default Rate                    | Eighteen percent (18.0%) per annum.  |
| (g) | Security Deposit                | \$5,000.00   |
| (h) | Brokers                         | None.  |
| (i) | Address for Notice to Landlord: | Hoschton Downtown Development Authority<br>Attn: Hoschton City Manager<br>61 City Square<br>Hoschton, GA 30542 |

To Tenant:	Atlanta Development Company, LLC Attn: Matt Ruppel 4725 Strickland Rd. Flowery Branch, GA 30542
------------	--

**LEASE PROVISIONS**

1.2. References And Conflicts. References appearing in Section 1.1 are to summarize provisions found in other places in this Lease applicable to the particular Fundamental Lease Provisions. Each reference in this Lease to any of the Fundamental Lease Provisions contained in Section 1.1 shall be construed to incorporate all of the terms provided for under such provisions, and such provisions shall be read in conjunction with all other provisions of this Lease applicable thereto. If there is any conflict between any of the Fundamental Lease Provisions set forth in Section 1.1 and any other provision of this Lease, the latter shall control.

1.3. Exhibits. The following drawings and special provisions are attached hereto as exhibits and hereby made a part of this Lease:

- (a) Exhibit "A" Floor Plan
- (b) Exhibit "B" Rent Schedule
- (d) Exhibit "C" Proposed Plans

**Article 2.**  
**Premises**

2.1. Lease Of Premises. Landlord hereby leases to Tenant, and Tenant hereby leases from Landlord, the Premises for the Term, at the Rent, and upon the covenants and conditions herein set forth.

2.2. Premises Defined. The term "Premises" means the interior space, totaling 2,344 square feet of the building known as **69 City Square**, as more particularly shown and labeled as "THE PREMISES" on Exhibit "A". In addition, Tenant will have access to utilize customer seating in the area under the City patio adjoining the Premises, whenever said patio is open to the general public.

2.3. Delivery Of Premises. Landlord has delivered possession to Tenant as an unbuilt-out shell. Landlord will deliver the Premises at Tenant on or before December 18, 2023, which for the purposes of this Lease will be the "Commencement Date".

**Article 3.**  
**Term**

3.1. Term Of This Lease. This Lease shall be the binding obligations of the parties as of the date it is signed. The Term of this Lease shall commence on the Commencement Date and shall continue through that date which is sixty (60) months after the Commencement Date.

3.2. Renewal Terms. This Lease may be renewed for two (2) additional five (5) year Terms, provided Tenant provides written notice of such extension no less than one-hundred eighty (180) days prior to the expiration of any existing Term.

**Article 4.**  
**Rent**

4.1. Tenant's Agreement To Pay Rent. Tenant hereby agrees to pay Rent.

4.2. Rent. The amount of Rent Tenant shall pay Landlord is:

(a) For the period beginning on the Commencement Date, and running through and including September 30, 2024 ("the Interim Period") Tenant will not be obligated to pay rent.

(b) Beginning on October 1, 2024, Rent will be as shown on Exhibit B. The Rent for each Lease Year shall be payable in twelve (12) equal monthly installments, in advance, on or before the first day of each calendar month.

4.3. Lease Year Defined. "Lease Year" means each successive twelve (12) month period after the Commencement Date. Any reference in this Lease to "Term" or "Lease Term" shall specifically include all extension or renewal options of this Lease exercised by Tenant.

4.4. Where Rent Payable And To Whom; No Deduction; Late Charge. Rent payable by Tenant under this Lease shall be paid to Landlord on or before the first day of each month, without prior demand therefore (except where such prior demand is expressly provided for in this Lease), without any deductions, set offs (except as hereinafter provided) or counterclaims whatsoever, at the place to which notices are to be sent to Landlord pursuant to Section 1.1(i) or to such payee and at such place as may be designated by Landlord to Tenant in writing at least ten (10) days prior to the next ensuing Rent payment date. If any payment of Rent or other charges due hereunder is not received by Landlord in good funds within ten (10) days from its due date, Tenant will pay to Landlord a late charge of five percent (5%) of the amount that is past due. In relation to the foregoing, Tenant acknowledges and agrees that such late payment charge represents an agreed upon charge for the administration expenses suffered by Landlord as a

result of such late payment and not a penalty or payment for the use of money. In addition to the above late charge, any amount due to Landlord, if not paid within ten (10) days of when due, shall bear interest from that date which is the tenth (10<sup>th</sup>) day following the date initially due until paid at a rate of eighteen percent (18%) per annum. Such late charges and late interest shall be in addition to any other remedies and damages to which Landlord may be entitled under this Lease, at law, or in equity.

**Article 5.**  
**Tenant's Conduct Of Business**

5.1. Hours. Tenant may operate Tenant's business during such hours as permitted by state and local ordinances or laws applicable to Tenant's business.

**Article 6.**  
**Use Of Premises**

6.1. Permitted Use. Throughout the Term, Tenant shall continuously use the Premises and operate in the same for the purpose specified in Section 1.1(e).

6.2. Requirements And Restrictions. Tenant agrees that it:

(a) will not use or permit the use of any apparatus for sound reproduction or transmission or of any musical instrument in such manner that the sounds so reproduced, transmitted or produced in violation of any applicable ordinance of the City of Hoschton;

(b) will keep all mechanical apparatus free of vibration and noise which may be transmitted beyond the confines of the Premises; will not cause or permit strong, unusual, offensive or objectionable noise, odors, fumes, dust or vapors to emanate or be dispelled from the Premises; will not burn trash or store or permit accumulations of any trash, garbage, rubbish or other refuse outside of the Premises except in compactors or other receptacles approved by Landlord;

(c) will not paint or decorate any part of the exterior of the Premises, or change the architectural treatment thereof, or install any visible protective devices such as burglar bars or security shutters or window tinting, without first obtaining Landlord's written approval; and will remove promptly upon order of Landlord any paint, decoration or protective device which has been applied to or installed upon the exterior of the Premises without Landlord's prior approval, or take such other action with reference thereto as Landlord may direct;

(d) will keep the inside and outside of all glass in the doors and windows of the Premises clean; will not place or maintain any merchandise, vending machines or other articles in the vestibule or entry of the Premises, on the foot walks adjacent thereto or elsewhere on the exterior thereof, will maintain the Premises at its own expense in a clean, orderly and sanitary condition and free of insect, rodents, vermin and other pests; and will keep refuse in proper containers on the interior of the Premises until removed from the Premises;

(e) will comply with all laws, rules, regulations, orders and guidelines relating to the Premises and will not use or permit the use of any portion of the Premises for any unlawful purpose;

(f) will not place, permit or maintain on the exterior walls or roof of the Premises any sign, advertising matter, decoration, lettering, insignia, emblems, trademark or descriptive material (herein called "Signs") other than as provided herein: and will maintain any and all Signs as may be approved in good condition and repair at all times, Landlord reserving the right to do so at Tenant's expense if Tenant fails to do so after five (5) days' notice from Landlord; Tenant acknowledges that it will install its approved Signs upon approval from both Landlord and the City of Hoschton and no more than 60 days after receiving such approval. Any signs placed by Tenant will be similar in size and style to those signs used by the City and/or Landlord relating to the other retail space in close proximity to the Premises.

6.3. Effect On The Building Insurance. Tenant shall not do or suffer to be done, or keep or suffer to be kept, anything in, upon or about the Premises which will contravene Landlord's policies insuring against loss or damage by fire or other hazards, or which will prevent Landlord from procuring such policies in companies acceptable to Landlord, or which will cause an increase in the insurance rates. If Tenant violates any prohibition provided for in the first sentence of this Section, Landlord may, after ten (10) days prior written notice to Tenant and Tenant's failure to cure such violation within said ten (10) day period, correct the same at Tenant's expense.

**Article 7.**  
**Liability, Indemnity And Insurance**

7.1. Landlord's Liability. To the maximum extent permitted by law, Landlord shall not be liable for any damage or liability of any kind or for any injury to or death of any persons or damage to any property on or about the Premises from any cause whatsoever, excepting only Landlord's sole negligence.

7.2. Indemnification.

(a) By Tenant. Tenant hereby agrees to indemnify and save Landlord harmless from all claims, actions, demands, costs and expenses and liability whatsoever, including reasonable attorneys' fees, on account of any damage or liability occasioned in whole or in part: by: (i) any use or occupancy of the Premises; (ii) any act or omission of Tenant, its agents, contractors, employees or invitees; and (iii) any occurrence within the Premises. Tenant shall not be liable for damage or injury occasioned by the gross negligence or willful acts of Landlord or its agents, contractors, or employees unless such damage or injury arises from perils against which Tenant is required by this Lease to insure.

(b) By Landlord. Subject to Section 7.1 above and the waiver of subrogation in Section 7.3 below, Landlord hereby agrees to indemnify and save Tenant harmless from all claims, actions, demands, costs and expenses and liability whatsoever, including reasonable attorneys' fees, on account of any damage or liability occasioned by the negligence of Landlord or its agents, contractors, and employees unless such damage or injury arises from perils against which Tenant is required by this Lease to insure.

The obligations of Tenant under Section 7.2(a) shall survive the expiration or termination of this Lease.

7.3. Mutual Waivers. Landlord and Tenant hereby waive any rights they may have against each other on account of any loss or damage occasioned to Landlord or Tenant, as the case may be, their property, the Premises, its contents, or arising from any risk covered by fire and extended coverage insurance maintained or required to be maintained hereunder by Landlord or Tenant, as the case may be. The parties hereto each, on behalf of their respective insurance companies insuring the property of either Landlord or Tenant against any such loss, waive any right of subrogation that it may have against Landlord or Tenant, as the case may be.

7.4. Tenant's Insurance.

(a) Tenant agrees that, from and after the date on which Tenant first enters into the Premises, Tenant shall carry at its sole cost and expense the following types of insurance, in the amounts specified and in the form hereinafter provided for:

(i) Commercial General Liability and Property Damage Insurance covering the Premises and Tenant's use thereof against claims for personal injury or death and property damage occurring upon, in or about the Premises, such insurance to afford protection to the limit of not less than \$1,000,000.00 combined single limit. The insurance coverage required under this Section 7.4(a)(i) shall, in addition, extend to any liability of Tenant arising out of the Indemnities provided for in Section 7.2 but shall not be deemed to limit or otherwise alter Tenant's liability hereunder;

(ii) Property Damage Insurance against "all-risks" of physical loss covering all of the items included in the Premises, Tenant's leasehold improvements, heating, ventilating and air conditioning equipment, trade fixtures, signage and personal property from time to time in, on or upon the Premises in an amount not less than their full replacement cost as such may change from time to time during the Term, providing protection against perils included within standard forms of fire and extended coverage Insurance policy, together with insurance against sprinkler damage, vandalism and malicious mischief. Any policy proceeds from such insurance shall be held in trust by Tenant for the repair, reconstruction, restoration or replacement of the property damaged or destroyed, unless this Lease shall cease and terminate under the provisions of this Lease;

(iv) Worker's Compensation Insurance in the minimum amounts required by the State of Georgia, and Employers' Liability Insurance in an amount not less than \$500,000.00 per occurrence; and

(v) Tenant will agree to cover plate glass damage as provided under its general property and casualty insurance coverages.

(vi) Business interruption coverage providing coverage in an amount equivalent to at least twelve (12) month's Rent for the applicable Lease Year.

(b) All policies of insurance provided for in Section 7.4(a) shall be issued in form reasonably acceptable to Landlord by insurance companies with general policyholder's rating of not less than A and a financial rating of Class X as rated in the most currently available "Best's Insurance Reports" and qualified to do business in the State of Georgia. Each such policy [except for the policy required under Section 7.4(a)(iv)] shall be issued in the name of Tenant and name as additional insureds Landlord and any other parties in interest from time to time designated in writing by Landlord to Tenant. Said policies shall be for the mutual and joint benefit and protection of Landlord and Tenant and executed copies of each such policy of insurance or a certificate thereof shall be delivered to Landlord within ten (10) days after delivery of possession of the Premises to Tenant and thereafter within thirty (30) days prior to the expiration of each such policy. As often as any such policy shall expire or terminate, renewal or additional policies shall be procured and maintained by Tenant in like manner and to like extent. All such policies of insurance shall contain a provision that the company writing said policy will give Landlord at least thirty (30) days' prior written notice of any cancellation, or lapse, or the effective date of any reduction in the amounts of insurance. All such commercial general liability, property damage, and other casualty policies shall be written on an "occurrence" rather than "claims made" basis and as primary policies which do not contribute to any policies which may be carried by Landlord or the Association. All such commercial general liability and property damage policies shall contain a provision that Landlord, although named as an additional insured, shall nevertheless be entitled to recover under said policies for any loss occasioned to it, its servants, agents and employees by reason of the negligence of Tenant. The minimum limits of such insurance policies to be maintained by Tenant shall be subject to increase from time to time if Landlord shall reasonably deem it necessary for adequate protection.

(c) Tenant agrees to permit Landlord at all reasonable times to inspect the policies of insurance of Tenant covering risks upon the Premises for which policies or copies thereof are not delivered to Landlord.

7.5. Landlord's Insurance. Landlord shall during the Term maintain in effect a policy or policies of insurance covering the Building housing the Premises [excluding Tenant improvements and property required to be insured by Tenant] in an amount not less than the full replacement cost protection against perils included within standard forms of fire and extended coverage insurance policies, together with insurance against sprinkler damage, vandalism, and malicious mischief, and such other risks as Landlord may from time to time determine and with any such deductibles as Landlord may from time to time determine and commercial general liability insurance in such amounts as Landlord deems to be reasonable.

7.6. Compliance With Insurance And Governmental Requirements. Tenant agrees at its own expense to comply with all reasonable requirements with respect to the Premises, or its use or occupancy, of the insurance underwriters and any similar public or private body, and any governmental authority having jurisdiction over insurance rates with respect to the use or occupancy of the Premises, including, but not limited to, installation of fire extinguishers or automatic dry chemical extinguishing systems, any changes, modifications or alterations in the sprinkler system or additional sprinkler heads or the location of partitions, trade fixtures or other contents of the Premises.

## **Article 8.** **Maintenance Of Premises**

8.1. Landlord's Duty To Maintain. Landlord will keep the roof, exterior walls, structural columns and structural floor or floors (excluding outer floor and floor coverings, doors, windows and glass) in good repair. Notwithstanding the foregoing provisions of this Section, Landlord shall not in any way be liable to Tenant on account of its failure to make repairs unless Tenant shall have given Landlord written notice of the necessity for such repairs and has afforded Landlord a reasonable opportunity to effect the same after such notice and provided that any damage arising therefrom shall not have been caused by Tenant's specific use of the Premises (i.e., as a restaurant), or the negligence or willful act or omission of Tenant, its agents, contractors, employees, and invitees (in which event Tenant shall be responsible therefor) or have been caused to any of the items Tenant is required to insure pursuant to Article 7.

8.2. Tenant's Duty To Maintain. Tenant will, at its own cost and expense, maintain the Premises (except that part Landlord has agreed to maintain) in good and tenantable condition, and make all repairs to the Premises and every part thereof as needed. Tenant's obligations under this Section shall include, but not be limited to, modifying, repairing and maintaining items as are required by any governmental agency having jurisdiction thereof (whether the same is ordinary or extraordinary, foreseen or unforeseen), interior walls and glass, and the interior portions of exterior walls, ceilings, utility meters, pipes and conduits within the Premises, and all utility meters, and all pipes and conduits outside the Premises between the Premises and the service meter, all fixtures all Tenant's signs, locks and closing

devices, and all window sash, casement or frames, doors and door frames; provided that Tenant shall make no adjustment, alteration or repair of any part of any sprinkler or sprinkler alarm system in or serving the Premises without Landlord's prior written approval.

8.3. Landlord's Repair Of Premises. Landlord shall be under no obligation to make any repairs, replacements, reconstruction, alterations, renewals, or improvements to or upon the Premises or the mechanical equipment exclusively serving the Premises except as expressly provided for herein.

**Article 9.**  
**Utilities And Garbage Disposal**

9.1. Water, Sanitary Sewer, Telephone And Electric Service. Tenant shall pay for all utilities and sanitary services used within the Premises and make such deposits to assure service as may be required by the utility or sanitary service company providing the same. Landlord shall not be in default hereunder or be liable for any damage directly or indirectly resulting from, nor shall the rental herein reserved be abated by reason of, the (i) installation, use, or interruption of use of any equipment in connection with the furnishing of any of the foregoing services or utilities, or (ii) failure to furnish or delay in furnishing any such services or utilities when such failure is caused by Acts of God or the elements, strikes, governmental orders, accidents, or other conditions beyond the reasonable control of the Landlord or by the making of repairs or improvements to the Premises or to the Building.

9.2. Garbage Collection. Tenant shall contract with the service company for the disposal of all trash and garbage from the Premises. Tenant shall be solely responsible for removing garbage from the Premises and placing it in the dumpster designated for the Premises.

**Article 10.**  
**Fixtures, Personal Property, And Signage**

10.1. Tenant's Property; Removal. Tenant shall have the right, provided Tenant is not in default, at any time and from time to time during the Term, to remove any and all of its trade fixtures, signs and other personal property which it may have stored or installed in the Premises, provided that any trade fixtures necessary for Tenant's operation shall be immediately replaced with similar personal property of comparable or better quality. Tenant, at its expense, shall immediately repair any damage occasioned to the Premises by reason of installation or removal of any such trade fixtures, signs and other personal property. If this Lease expires or is terminated for any reason except termination by Landlord and Tenant fails to remove such items from the Premises prior to such expiration or termination, or if this Lease is terminated by Landlord and Tenant fails to remove such items from the Premises on or before the effective date of such termination, then in any such event all such trade fixtures, signs and other personal property shall thereupon become the property of Landlord, without further act by either party hereto, unless Landlord elects to require their removal, in which case Tenant agrees to promptly remove same and restore the Premises to its prior condition at Tenant's expense. The obligations of Tenant under this Section 10.1 shall survive the termination or expiration of this Lease.

**Article 11.**  
**Taxes**

RESERVED

**Article 12.**  
**Assignment And Subletting**

12.1. Restrictions On Assignment. The terms of this Lease, including the provisions relating to Rent and Use, have been negotiated by Landlord and Tenant on the assumption that Tenant will be the occupant of the Premises for the full Term. The parties have therefore agreed that Tenant shall have no right to advertise that any portion of the Premises is available for lease, transfer, assign, sublet, enter into license or concession agreements, or mortgage or hypothecate this Lease or the Tenant's interest in the Premises or any part thereof without Landlord's consent (any of the events listed herein being a "Transfer"), which consent shall be issued or withheld in Landlord's sole, but good faith, discretion. Any attempted Transfer shall be void and confer no rights upon any third person. Any transfer of this Lease from Tenant by merger, consolidation, liquidation or otherwise by operation of law including, but not limited to, an assignment for the benefit of creditors, shall be included in the term "Transfer" for the purposes of this Lease and shall be a violation of this Section. Notwithstanding anything contained herein to the contrary, Tenant may Transfer Tenant's obligations under this Lease to an affiliate or subsidiary of Tenant without prior approval.

12.2. Change of Ownership. A transfer, assignment or hypothecation of any ownership interest in Tenant's limited liability company by any member or owner so as to result in a change in the control thereof by the person, persons or entities owning a majority interest therein as of the date of this Lease, shall be deemed to be a Transfer of this Lease.

**Article 13.**  
**Alterations To Premises**

13.1. Alterations; Damages. Except as specifically reflected in Exhibit C, Tenant shall make no structural or external alterations, additions or changes in or to the Premises nor shall Tenant make any alterations, additions or changes to the Building's mechanical or utility systems without Landlord's prior written consent, nor shall Tenant make any alterations, additions or changes of any nature that are in excess of Ten Thousand Dollars (\$10,000.00) cumulatively without Landlord's prior written consent. In no event shall Tenant make or cause to be made any penetration through any roof, floor or exterior or corridor wall without the prior written consent of Landlord. Tenant shall be responsible for any and all damages resulting from any alteration, addition or change Tenant makes, whether or not Landlord's consent therefor was obtained. Any and all alterations, additions and changes made to the Premises which are consented to by Landlord shall be made under the supervision of a licensed architect or a licensed structural engineer and in accordance with plans and specifications, and all necessary governmental approvals and permits, which approvals and permits Tenant shall obtain at its sole expense.

13.2. Compliance With Laws. Any permitted changes, alterations and additions made by Tenant shall be performed strictly in accordance with applicable laws, rules, regulations and building codes relating thereto.

13.3. Insurance And Reconstruction. In the event Tenant shall make any alterations, additions or changes to the Premises, none of such alterations, additions or changes need be insured by Landlord under such insurance as Landlord may carry upon the Building, nor shall Landlord be required under any provisions of this Lease to reconstruct or reinstall any such alterations, additions or changes in the event of casualty loss.

**Article 14.**  
**Reconstruction**

14.1. Landlord's Duty To Reconstruct. In the event the Building is damaged or destroyed by any of the risks against which Landlord has procured insurance, Landlord shall (subject to being able to obtain all necessary permits and approvals therefor), within sixty (60) days after such damage or destruction (unless Landlord terminates this Lease), commence to repair, reconstruct and restore or replace the Building so insured by Landlord and prosecute the same diligently to completion. In no event shall Landlord be liable for interruption to business of Tenant or for damage to or repair, reconstruction, restoration or replacement of any of those items which Tenant is required to insure, nor shall Landlord be required to expend more for any repair, reconstruction, restoration, or replacement of the Building pursuant to this Section than the amount of insurance proceeds paid to Landlord in connection therewith plus the amount of any applicable deductible. Further, in no event shall Landlord be liable to Tenant for performing any repair, reconstruction, restoration or replacement for which Landlord does not actually receive insurance proceeds.

14.2. Tenant's Duty To Reconstruct. If any item which Tenant is required to insure damaged or destroyed by any of the risks referred to therein, Tenant shall, within sixty (60) days thereafter, commence to repair, reconstruct and restore or replace said matters and prosecute the same diligently to completion.

14.3. Abatement Of Rent. If this Lease is not terminated by Landlord and if the Premises have been rendered wholly or partially untenantable by such damage or destruction, then the Rent payable by Tenant under this Lease during the period the Premises are untenantable shall be abated in its entirety in the event the Tenant is unable to operate Tenant's business in the Premises.

14.4. Tenant's Right To Terminate. If Landlord fails to commence the restoration within 60 days after the casualty, Tenant shall have the right to terminate this Lease by written notice to Landlord given prior to Landlord's commencement of the restoration work.

**Article 15.**  
**Hazardous Substances**

15.1. Restriction On Use. Tenant shall not use or permit the use of the Premises for the generation, storage, treatment, use, transportation, handling or disposal of any chemical, material or substance which is regulated as toxic or hazardous or exposure to which is prohibited, limited or regulated by any governmental authority, or which,

even if not so regulated, may or could pose a hazard to the health or safety of persons on the Premises or other tenants or occupants or property adjacent thereto, and no such chemical, material or substance shall be brought onto the Premises without Landlord's express written approval. Tenant agrees that it will at all times observe and abide by all laws and regulations relating to the handling of such materials and will promptly notify Landlord of (a) the receipt of any warning notice, notice of violation, or complaint received from any governmental agency or third party relating to environmental compliance and (b) any release of hazardous materials on the Premises. Tenant shall carry out, at its sole cost and expense, any remediation required as a result of the release of any hazardous substance by Tenant or by Tenant's agents, contractors, employees, or invitees, from the Premises. Notwithstanding the foregoing, Tenant shall have the right to bring on to the Premises reasonable amounts of cleaning materials and the like necessary for the operation of the Tenant's business as set forth in Section 1.1(e), but Tenant's liability with respect to such materials shall be as set forth in this Article.

15.2. Indemnification. Tenant agrees to indemnify and save Landlord harmless from all liability, costs and claims, including attorney's fees, resulting from any environmental contamination on the Premises caused by Tenant or its agents, contractors, employees or invitees, including the cost of remediation and defense of any action for any violation of this provision.

15.3. Survival. The provisions of this Article shall survive the termination or expiration of this Lease.

## Article 16.

### Liens

16.1. No Liens Permitted; Discharge. The Landlord's property shall not be subject to liens for work done or materials used on the Premises made at the request of, or on order of or to discharge an obligation of, Tenant. This paragraph shall be construed so as to prohibit, in accordance with the provisions of State law, the interest of Landlord in the Premises or any part thereof from being subject to any lien for any improvements made by Tenant or any third-party on Tenant's behalf (except Landlord) to the Premises. If any lien or notice of lien on account of an alleged debt of Tenant or any notice of lien by a party engaged by Tenant or Tenant's contractor to work on the Premises shall be filed against the Premises or any part thereof, Tenant, within ten (10) days after notice of the filing thereof, will cause the same to be discharged of record by payment, deposit, bond, order of a court of competent jurisdiction or otherwise. If Tenant shall fail to cause such lien or notice of lien to be discharged within the period aforesaid, then, in addition to any other right or remedy, Landlord may discharge the same either by paying the amounts claimed to be due or by procuring the discharge of such lien by deposit or by bonding procedures. Any amount so paid by Landlord and all costs and expenses, including reasonable attorneys' fees, incurred by Landlord in connection therewith, and including interest at the Default Rate, shall constitute additional Rent and shall be paid by Tenant to Landlord on demand. Nothing herein shall obligate Tenant to pay or discharge any lien created by Landlord. The obligations of Tenant under this Section 16.1 shall survive the termination or expiration of this Lease.

## Article 17.

### Defaults By Tenant

17.1. Events Of Default. This Lease is made upon the condition that Tenant shall punctually and faithfully perform all of the covenants, conditions and agreements by it to be performed. Any notice of default required to be given by Landlord hereunder shall be given to Tenant. The following shall each be deemed to be an event of default (each of which is sometimes referred to as an "Event of Default") in this Lease:

(a) any part of the Rent required to be paid by Tenant under this Lease shall at any time be unpaid for ten (10) days after Rent is due;

(b) Tenant fails in the observance or performance of any of its other covenants, agreements or conditions provided for in this Lease, and said failure shall continue for a period of ten (10) days after written notice thereof from Landlord to Tenant;

(c) the estate created in Tenant hereby is taken in execution or by other process of law, or all or a substantial part of the assets of Tenant is placed in the hands of a liquidator, receiver or trustee (and such receivership or trusteeship or liquidation continues for a period of ten (10) days), or Tenant makes an assignment for the benefit of creditors, or admits in writing that it cannot meet its obligations as they become due, or is adjudicated as bankrupt, or Tenant institutes any proceedings under any federal or state insolvency or bankruptcy law as the same now exists or under any amendment thereof which may hereafter be enacted, or under any other act relating to the subject of bankruptcy wherein the Tenant seeks to be adjudicated as bankrupt, or to be discharged of its debts, or to effect a plan of liquidation, composition or reorganization, or should any involuntary proceedings be filed against Tenant



under any such insolvency or bankruptcy law (and such proceeding not be removed within ninety (90) days thereafter). If any insolvency proceedings, such as those referred to in this Section, are instituted against Tenant, the Premises shall not become an asset in any such proceedings; or

(d) any default by Tenant under any security agreements hereof.

(e) Tenant's failure to execute and deliver to Landlord within ten (10) days of Landlord's request any instrument as may be required by Landlord under the provisions of this Lease.

17.2. Landlord's Remedies. If any Event of Default occurs, then and in such case Landlord may treat the occurrence of such Event of Default as a breach of this Lease and, in addition to any and all other rights and remedies of Landlord in this Lease or by law or in equity provided, it shall be, at the option of Landlord, without further notice or demand to Tenant or any other person, the right of Landlord to:

(a) declare the Term ended and to enter the Premises and take possession thereof and remove all persons therefrom, and Tenant shall have no further claim thereon or thereunder;

(b) bring suit for the collection of Rent as it accrues pursuant to the terms of this Lease and damages without entering into possession of the Premises or canceling this Lease;

(c) with or without terminating this Lease, retake possession of the Premises from Tenant by summary proceedings or otherwise. Landlord may, but shall be under no obligation to, relet the Premises or any portion thereof after such retaking possession. Tenant shall pay to Landlord all monthly deficits in Rent after any such re-entry in monthly installments as the amounts of such deficits from time to time are ascertained. Such deficiency shall be calculated and paid monthly; Tenant shall have no right to any excess. Tenant shall also pay to Landlord any costs and expenses, including, but not limited to, brokerage commissions and attorneys' fees, incurred by Landlord in such reletting or in making such alterations and repairs not covered by the rental received from such reletting. In the event of an entry or taking possession of the Premises as aforesaid, Landlord shall have the right, but not the obligation, to remove therefrom all or any part of the personal property located therein and may place the same in storage at a public warehouse at the expense and risk of the owner or owners thereof.

17.3. Attorneys' Fees And Costs. Tenant agrees to reimburse Landlord for the costs and attorneys' fees incurred by Landlord by reason of any Event of Default by Tenant, including reasonable attorneys' fees and costs in connection with trial and appellate proceedings.

17.4. Tenant's Property To Remain. If there is an Event of Default, all of the Tenant's fixtures, furniture, equipment, improvements, additions, alterations, and other personal property shall remain on the Premises and, in that event and continuing during the length of said default, Landlord shall have the right to take the exclusive possession of same, without cost, until all defaults are cured or, at its option, at any time during the Term to require Tenant to forthwith remove same.

## **Article 18.** **Liability Of Landlord**

18.1. Landlord's Default. Except as otherwise provided in this Lease, Landlord shall be in default under this Lease if Landlord fails to perform any of its obligations hereunder and said failure continues for a period of thirty (30) days after written notice thereof from Tenant to Landlord (unless such failure cannot reasonably be cured within thirty (30) days and Landlord shall have commenced to cure said failure within said thirty (30) days and continues diligently to pursue the curing of the same).

18.2. Transfer Of Landlord's Interest. In the event of the sale or other transfer of Landlord's interest in the Premises (except in connection with financing obtained by Landlord), Landlord shall transfer and assign to such purchaser or transferee the Security Deposit and Landlord's rights under this Lease, and Landlord thereupon and without further act by either party shall be released from all liability and obligations hereunder arising out of any act, occurrence or omission relating to the Premises or this Lease occurring after the consummation of such sale or transfer. Tenant agrees to attorn to any successor, assign, mortgagee or ground lessor of Landlord.

**Article 19.**  
**Quiet Enjoyment**

19.1. **Faithful Performance.** Upon payment by Tenant of the Rent herein provided for and upon the observance and performance of all of the agreements, covenants, terms and conditions on Tenant's part to be observed and performed, Tenant shall peaceably and quietly hold and enjoy the Premises for the Term without hindrance or interruption by Landlord or any other person or persons lawfully or equitably claiming by, through or under Landlord.

**Article 20.**  
**Surrender And Holding Over**

20.1. **Delivery After Term.** Tenant shall deliver up and surrender to Landlord possession of the Premises upon the expiration or earlier termination of the Term, broom clean, free of debris, in good order, condition and state of repair (except ordinary wear and tear and damage due to casualty not caused by Tenant, its employees, agents, contractors and invitees), and shall deliver the keys to Landlord at the address to which notices to Landlord are to be sent pursuant to Section 1.1(i). If not sooner terminated as herein provided, this Lease shall terminate at the end of the Term as provided for in Article 3 without the necessity of notice from either Landlord or Tenant to terminate the same, Tenant hereby waiving notice to vacate the Premises and agreeing that Landlord shall be entitled to the benefit of all provisions of law respecting the summary recovery of possession of premises from a tenant holding over.

20.2. **Effect Of Holding Over; Rent.** If Tenant remains in possession of the Premises after expiration of the Term, with Landlord's acquiescence and without any express agreement of the parties, Tenant shall be a tenant-at-sufferance at a rental rate equal to one hundred twenty-five percent (125%) times the Rent in effect at the end of this Lease and there shall be no renewal of this Lease by operation of law. The acceptance by Landlord of rent in the event of a Tenant holdover shall not result in the renewal of this Lease and shall in no way be deemed to constitute Landlord's consent to such holdover by Tenant. If Tenant fails to surrender the Premises after expiration or termination of the Lease Term, Tenant shall indemnify, defend and hold harmless Landlord from all loss or liability, including, without limitation, any loss or liability resulting from any claim against Landlord made by any succeeding tenant founded on or resulting from Tenant's failure to surrender and losses to Landlord due to lost opportunities to lease any portion of the Premises to succeeding tenants, together with, in each case, actual attorneys' fees and costs.

**Article 21.**  
**Condemnation**

21.1. **All Of Premises Taken.** If the whole of the Premises shall be taken either permanently or temporarily by any right of eminent domain or conveyance in lieu thereof (each being hereinafter referred to as "**Condemnation**"), this Lease shall terminate as of the day possession shall be taken by the condemning authority, and Tenant shall pay Rent and perform all of its other obligations under this Lease up to that date with a proportionate refund by Landlord of any Rent that may have been paid in advance for a period subsequent to the date of taking.

21.2. **Less Than All Of Premises Taken.** If less than all but more than twenty percent (20%) of the GLA in the Premises is taken by condemnation or if (regardless of the percentage of the GLA in the Premises which is taken) the remainder of the Premises is not one undivided parcel of property, then in either event Landlord and Tenant shall have the right to terminate this Lease upon notice in writing to the other party within ninety (90) days after possession is taken by such condemnation. If this Lease is so terminated, it shall terminate as of the day possession shall be taken by such authority, and Tenant shall pay Rent and perform all of its other obligations under this Lease up to that date with a proportionate refund by Landlord of any Rent that may have been paid in advance for a period subsequent to the date of the taking. If this Lease is not so terminated, it shall terminate only with respect to the parts of the Premises so taken as of the day possession is taken by such authority, and Tenant shall pay Rent up to that day with a proportionate refund by Landlord of any Rent that may have been paid for a period subsequent to the date of the taking and, thereafter, the Rent shall be based on the square footage of GLA in the Premises. Landlord agrees, at Landlord's cost and expense, as soon as reasonably possible (but subject to being able to obtain all necessary permits and approvals therefore), to restore the Premises to a complete unit of like quality and character as existed prior to such appropriation or taking; provided that Landlord shall not be required to expend more on such restoration than the condemnation award received by Landlord (less all expenses, costs, legal fees and court costs incurred by Landlord in connection with such award).

21.3. **Ownership Of Award.** All damages for any condemnation of all or any part of the Premises owned by Landlord, including, but not limited to, all damages as compensation for diminution in value of the leasehold, reversion, and fee, shall belong to the Landlord without any deduction therefrom for any present or future estate of Tenant, and Tenant hereby assigns to Landlord all its right, title and interest to any such award. Although all damages

in the event of any condemnation are to belong to the Landlord, Tenant may have the right to claim and recover from the condemning authority, but not from Landlord, such compensation as may be separately awarded or recoverable by Tenant in Tenant's own right on account of any and all damage to Tenant's business by reason of the condemnation and for or on account of any cost or loss which Tenant might incur in removing Tenant's merchandise, furniture, fixtures, leasehold improvements and equipment, provided any such award to Tenant shall not reduce the amount of the award to Landlord.

**Article 22.**  
**Operating Costs**

RESERVED

**Article 23.**  
**Miscellaneous**

23.1. Interpretation.

(a) The captions appearing in this Lease are inserted only as a matter of convenience and in no way amplify, define, limit, construe or describe the scope or intent of such sections of the Lease.

(b) The neuter, feminine or masculine pronoun when used herein shall each include each of the other genders and the use of the singular shall include the plural.

(c) Although the printed provisions of this Lease were drawn by Landlord, this Lease is the product of negotiations between Landlord and Tenant and shall not be construed for or against Landlord or Tenant.

(d) Notwithstanding any other provision of this Lease, if the state in which the Premises is located recognizes a distinction between an estate for years and a "usufruct," it is the intention of the parties for this instrument to create a usufruct and not an estate for years.

23.2. Relationship Of Parties. Nothing herein contained shall be construed as creating any relationship between the parties other than the relationship of landlord and tenant, nor cause either party to be responsible in any way for the acts, debts or obligations of the other.

23.3. Notices.

(a) Any notice, demand, request, approval, consent or other instrument which may be or is required to be given under this Lease shall be in writing and shall be sent to the party to be notified by United States certified mail, return receipt requested, postage prepaid, or by a nationally recognized overnight delivery service (such as, but not limited to, Federal Express) or by hand delivery addressed to the party to be notified at the address of such party set forth in Section 1.1(i), or to such other address as such party may from time to time designate by notice to the other in accordance with this Section. Any such notice shall be deemed given on the date on which such notice is deposited in the United States Mail or with the overnight delivery service or hand delivery, but the timeframe in which a response must be given shall commence on the date on which the notice is delivered (or delivery if first attempted in the event of a change of address of which the other party was not informed in accordance with this Section or if delivery is rejected).

(b) No notice required to be given to Landlord shall be effective for any purpose unless and until a true copy thereof is given to each mortgagee of Landlord's estate, provided Tenant has previously been given written notice of the name and address of such mortgagee.

23.4. Successors. This Lease shall inure to the benefit of and be binding upon Landlord, its successors and assigns and Tenant and its permitted successors and assigns.

23.5. Broker's Commission. Tenant warrants that it has dealt with no broker in connection with this and shall indemnify and hold Landlord harmless from and against any claims, actions, demands, fees, costs or expenses pertaining or related to any broker or other party claiming a commission or a monetary interest in the transaction contemplated by this Lease due to such broker/party's participation or alleged participation in said transaction on Tenant's behalf.

23.6. Entire Agreement.

(a) There are no oral agreements between the parties hereto affecting this Lease, and this Lease supersedes and cancels any and all previous negotiations, arrangements, letters of intent, lease proposals, brochures, agreements, representations, promises, warranties and understandings between the parties hereto or displayed by Landlord to Tenant with respect to the subject matter thereof.

(b) This Lease, including the Exhibits and any addenda, sets forth all the covenants, promises, agreements, conditions and understandings between Landlord and Tenant concerning the Premises. No alteration, amendment, change or addition to this Lease shall be binding upon Landlord or Tenant unless reduced in writing, signed by them and mutually delivered between them.

23.7. Applicable Law. The laws of the State of Georgia shall govern the validity, performance and enforcement of this Lease.

23.8. Waiver.

(a) The waiver by either party of any term, covenant, agreement or condition herein shall not be deemed to be a waiver of any subsequent breach of the same or any other term, covenant, agreement or condition. The acceptance of Rent hereunder by Landlord shall not be deemed to be a waiver of any prior default by Tenant, other than the failure of Tenant to pay the particular Rent so accepted, regardless of Landlord's knowledge of such prior default at the time of acceptance of such Rent. No covenant, term, agreement or condition of this Lease shall be deemed to have been waived by either party unless such waiver be in writing by such party.

(b) No waiver of any covenant, term, agreement or condition of this Lease or legal right or remedy shall be implied by the failure of Landlord to declare a default, or for any other reason. No waiver by Landlord in respect to one or more tenants or occupants of the Premises shall constitute a waiver in favor of any other tenant. Landlord's consent to, or approval of, any act by Tenant requiring Landlord's consent or approval shall not be deemed to waive or render unnecessary Landlord's consent to or approval of any subsequent similar act by Tenant.

23.9. Accord And Satisfaction. No payment by Tenant or receipt by Landlord of a lesser amount than the Rent herein stipulated shall be deemed to be other than on account of the earliest stipulated Rent, nor shall any endorsement or statement on any check or any letter accompanying any such check or payment as Rent be deemed an accord and satisfaction, and Landlord may accept such check or payment without prejudice to Landlord's right to recover the balance of such Rent or pursue any other remedy provided for in this Lease or available at law or in equity.

23.10. Landlord's Self-Help. In addition to Landlord's rights of self-help set forth elsewhere in this Lease, if Tenant at any time fails to perform any of its obligations under this Lease in a manner reasonably satisfactory to Landlord, Landlord shall have the right, but not the obligation, upon giving Tenant at least ten (10) days' prior written notice of its election to do so (in the event of an emergency, no prior notice shall be required), to perform such obligations on behalf of and for the account of Tenant and to take all such action necessary to perform such obligations. In such event, Landlord's reasonable costs and expenses incurred therein shall be paid for by Tenant as additional Rent, forthwith upon demand therefore, with interest thereon from the date Landlord performs such work at the Default Rate. The performance by Landlord of any such obligation shall not constitute a release or waiver of Tenant therefrom.

23.11. Recording. Tenant agrees that it will not record the Lease. Tenant may record a Memorandum of Lease approved by and with the written consent of Landlord.

23.12. Counterparts. This Lease may be executed in more than one counterpart, and each such counterpart shall be deemed to be an original document.

23.13. Severability. Each covenant and agreement in this Lease, including, but not limited to Tenant's covenant to pay Rent, shall for all purposes be construed to be a separate and independent covenant or agreement. If any provision in this Lease or the application thereof shall to any extent be held to be invalid, illegal or otherwise unenforceable by a court of competent jurisdiction, the remainder of this Lease, and the application of such provision other than as invalid, illegal, or unenforceable, shall not be affected thereby; and such provisions in this Lease shall be valid and enforceable to the fullest extent permitted by law.

23.14. Time Of The Essence. Time is of the essence of each and every obligation under this Lease.

23.15. Landlord's Representations and Warranties. Landlord represents and warrants that it has lawful title to the Premises and has full right, power and authority to enter into this Lease.

26.20. Representations by Tenant. The persons executing this Lease on behalf of Tenant hereby covenant and warrant that Tenant is a duly qualified limited liability company authorized to do business in the State of Georgia, and the person signing this Lease on behalf of the company duly authorized to sign and execute this Lease. Tenant hereby represents and warrants that: (a) there are no proceedings pending or so far as Tenant knows threatened before any court or administrative agency that would materially adversely affect the financial condition of Tenant, the ability of Tenant to enter into this Lease or the validity or enforceability of this Lease; (b) there is no provision of any existing mortgage, indenture, contract or agreement binding on Tenant which would conflict with or in any way prevent the execution, delivery or performance of the terms of this Lease; Tenant acknowledges that Landlord is executing this Lease in reliance upon the foregoing representation and warranty and that such representation and warranty is a material element of the consideration inducing Landlord to enter into and execute this Lease.

26.21 Ambiguities/Rule of Construction. The parties acknowledge that each party and its counsel have reviewed and approved this Lease and that the normal rule of construction to the effect that any ambiguities are to be resolved against the drafting party shall not be employed in the interpretation of this Lease or any amendments or exhibits hereto.

**Article 24.**  
**Security Deposit**

24.1. Security Deposit. Tenant will pay at the time of the execution of this agreement a Security Deposit in the amount of \$5,000.00.

**Article 25.**  
**Buildout Costs**

25.1 Buildout. Tenant will be responsible for buildout of the space

25.2 Windows. Landlord acknowledges that as a part of the Buildout, Tenant intends to add additional windows on the North side of the Premises with final plans subject to Landlord approval.

**IN WITNESS WHEREOF,** Landlord and Tenant have duly executed this Lease as of the day and year first above written.

**LANDLORD:**

HOSCHTON DOWNTOWN DEVELOPMENT AUTHORITY

\_\_\_\_\_  
Witness

By: \_\_\_\_\_  
Name: \_\_\_\_\_  
Its: \_\_\_\_\_

\_\_\_\_\_  
Notary Public  
My Commission expires:

[Notary Seal]

**TENANT:**

ATLANTA DEVELOPMENT COMPANY, LLC

\_\_\_\_\_  
Witness

By: \_\_\_\_\_  
Name: \_\_\_\_\_  
Its: \_\_\_\_\_

\_\_\_\_\_  
Notary Public  
My Commission expires:

[Notary Seal]

**Exhibit A Description of Premises**

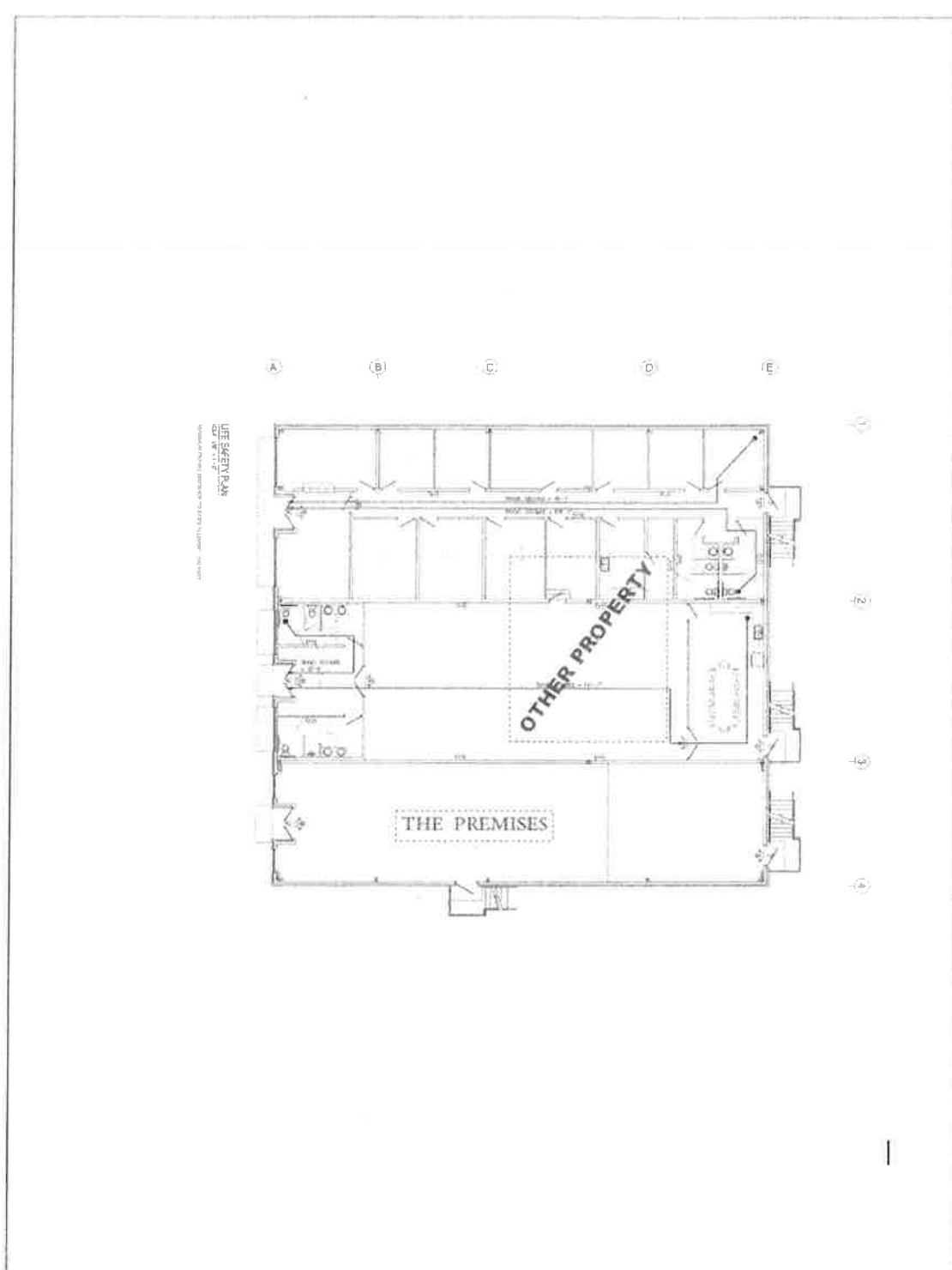

LIFE SAFETY PLAN  
 CITY OF HOUGHTON  
 10/1/11

<p>PROJECT NO. 1511</p>	<p>LIFE SAFETY PLAN</p>	<p>CITY OF HOUGHTON          CITY OF HOUGHTON          10/1/11</p>	<p>NEW CITY HALL</p>	<p>DATE: 10/1/11          DRAWN BY: [Name]          CHECKED BY: [Name]</p>		<p><b>Garland</b>          &amp; Associates Contractors, Inc.          GENERAL CONTRACTORS          10261 Garland Dr - Suite 400          PO Box 370          Saginaw, MI 49782          www.garland-associates.com          Commercial • Industrial • Design/Build</p>	<p>Phone: 770-725-9000          Fax: 770-725-1900</p>

**EXHIBIT B**  
**RENT SCHEDULE**

"INTERIM PERIOD"	No Rent Payable
FIRST FIVE (5) YEAR TERM (Starting 10/1/2024)	- \$1,500.00 PER MONTH
SECOND FIVE (5) YEAR TERM	- \$3,106.25 PER MONTH
THIRD FIVE (5) YEAR TERM	- \$3,261.56 PER MONTH





# NEW BUSINESS

## ITEM #1

Final Plat for Creekside Village Towns



# Jerry Weitz & Associates, Inc. Planning & Development Consultants

1225 Rucker Road, Alpharetta, Georgia 30004  
Phone: (404) 502-7228 E-Mail: jweitz@bellsouth.net

Growth Management  
Comprehensive Planning  
Zoning & Land Use Regulations  
Land Development Applications  
Expert Testimony  
Zoning Administration

## MEMORANDUM

TO: Honorable Mayor and City Council, City of Hoschton

FROM: Jerry Weitz, Consulting City Planner

DATE: January 4, 2024

RE: Hoschton City Council January 11, 2024, Agenda Item. **Final Plat for Creekside Village Towns:** Premier Residential Builders Georgia, LLC, by Harold A. Trip, Jr., applicant, UTR Hoschton, LLC, c/o Anthony Criscione, property owner, 31 lots on 3.03 acres fronting on the south side of Eagles Bluff Way and including the dedication of Creekside Commons Drive. Zoning is MU, Mixed Use District (Z-19-02). Proposed use: fee simple townhouses

---

The above-referenced item has been approved for the above-referenced work session agenda.

### PROCESS OVERVIEW

A final plat for a major subdivision is required to be approved by City Council (Reference: Sec. 303 subdivision and land development ordinance).

Requested/ recommended action: Approval of final plat.

A vote of approval authorizes the mayor to sign the plat and formally accepts the water and sewer lines. Approval of the final plat also accepts the aforementioned streets as public dedications but does not accept the streets for maintenance (a step which comes later, see below). A preliminary plat was previously approved by the City Council. Land disturbance and development plans were previously approved by the planning and zoning department.

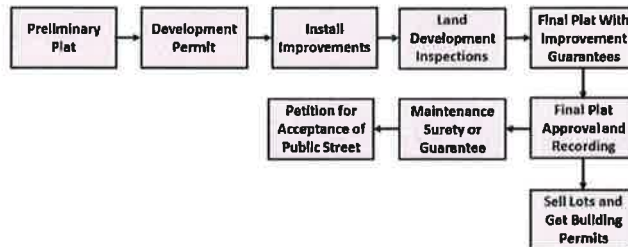

Overview of the Subdivision and Development Process  
(With Public Street or Public Improvement)

Source: Sec. 306, Subdivision and Land Development Ordinance

**CRITERIA AND FINDINGS FOR FINAL PLAT APPROVAL**

Final plat approval shall be granted if the following criteria are met (Reference: Sec. 1004 Subdivision and Land Development Ordinance). Staff findings relative to these criteria follow.

***Criterion: A preliminary plat of the proposed subdivision, if required, has been previously approved by the Hoschton City Council.***

Finding: A preliminary plat was never submitted or proposed because the development project was permitted as a non-subdivided project (condominium ownership or rental). The application therefore does not meet this criterion. However, the applicant applied for and received variances that basically will enable the project to become a fee simple townhouse subdivision instead of a condominium or apartment project. The variance approvals implied that the applicant would be able to proceed directly to final plat approval without having to file a preliminary plat after the land disturbance and land development process was completed.

**Criteria: Where new improvements are involved in the subdivision, development plans have been approved by the Zoning Administrator, all improvements have been installed, improvements have been inspected by the Zoning Administrator and/or City Engineer, and subdivision improvement guarantees as required by this Ordinance have been submitted. A complete final plat application has been submitted, including all supporting materials required by this Ordinance for final plats.**

Finding: Development plans were previously reviewed and approved. See the table below for specific status and notes.

Status/ disposition	Submission Required	Notes
Received	Application fee	\$1,800
Received	Copies of final plat; pdf copy	Included (overall image)
In process	City Engineer review and approval including as-built drawings	The review process is underway as of 1/04/24 and is to be expedited; video of sewer received; water line re-chlorinated 3.5 months ago
In process	Field inspection by Land Development Inspector/ Public Works Director	Road turnaround is subject to additional inspection
Not applicable	External agency review obtained if required	Not applicable
Received; routed to city engineer	Submission to City Engineer of electronic files for as-builts	Subject to confirmation prior to release for recording
	Street signs, traffic signs, and pavement markings installed/completed	Subject to confirmation
	Receipt for payment of street lights	In process
n/a (existing)	Homeowner's association created; documents reviewed	Project will be included under Creekside Village homeowner's association
	Subdivision improvement guarantee: Maintenance bond for public improvements	Not yet received; expected by date of work session

Complete	Confirmation 3 <sup>rd</sup> party inspection of streets for asphalt thickness, density, compaction	3 <sup>rd</sup> party engineer analysis is on record
----------	---	--

***Criterion: The final plat meets all applicable requirements of this Ordinance.***

The road, name Creekside Commons Drive, proposed to be a public street, does not meet the requirements of the Hoschton subdivision and land development ordinance because it was built without the intentions of it becoming a public or private street upon which lots would be subdivided. It does not have the minimum width of 26 feet from back of curb to back of curb. However, the applicant sought and City Council granted a variance to this requirement (V-23-05 approved in December 2023). Also, the road does not have a circular cul-de-sac at the end. This issue was discussed in the staff report for V-23-05 and V-23-06 pertaining to the subject property. Basically, one of the reasons why the applicant did not construct a circular turnaround is because the city insisted on the dedication of the prior (southern) portion of the site to the city for a water tank site. That dedication left the parcel with insufficient land to construct a turnaround. A "hammerhead" type turnaround is in the process of being paved to serve the street.

Lots do not meet the minimum area requirements of Sec. 6.55 of the zoning ordinance. However, a variance was applied for and granted (V-23-06) by the City Council to reduce the minimum lot area from 2,400 square feet to 1,800 square feet for some but not all lots, and other variances were given to Sec. 6.55 of the zoning ordinance.

**CONCLUSION**

Staff recommendation is approval even though the applicant is still in the process of completing all requirements.



Tax Map/Aerial Photograph

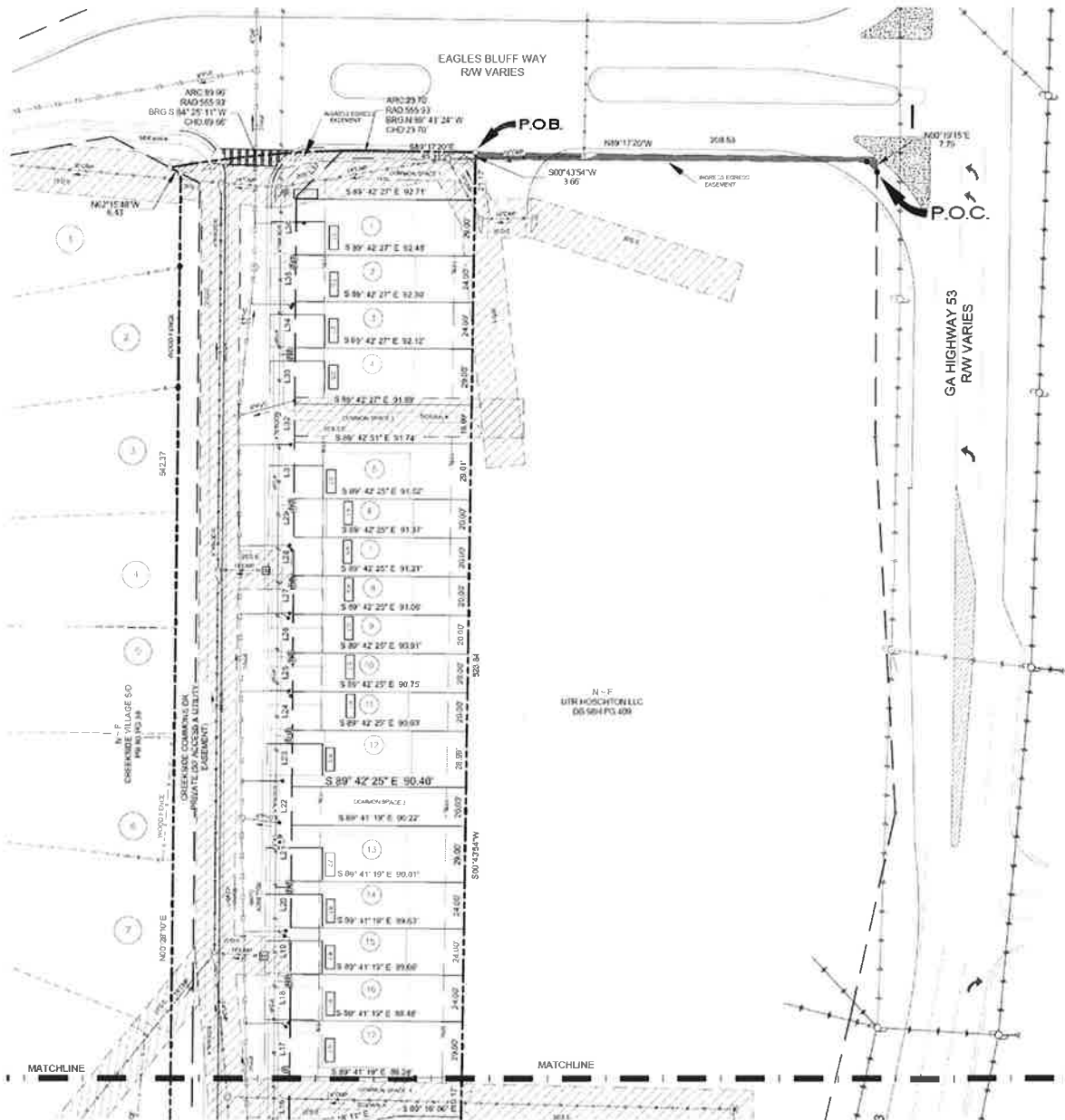

Excerpt (1 of 2) of Proposed Final Plat, Northern Portion of Site (Lots 1-17)  
(original submission)

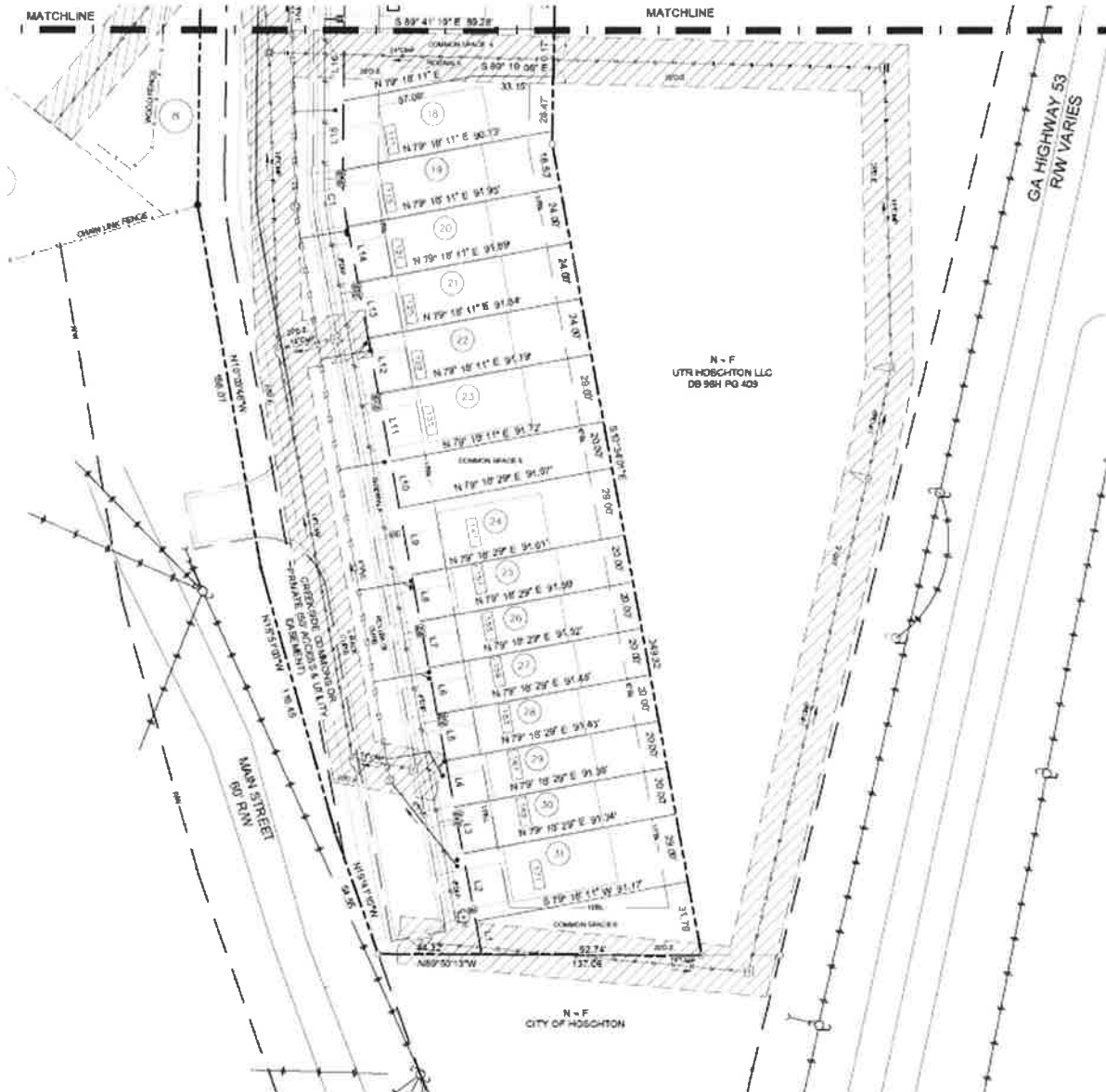

Excerpt (2 of 2) of Proposed Final Plat, Southern Portion of Site (Lots 18-31)  
(original submission)

# NEW BUSINESS

## ITEM #2

Authorization to initiate actions to reactivate  
Planning & Zoning Commission

(no documentation)



# NEW BUSINESS

## ITEM #3

Ordinance 0-24-01:

Narrow Strip Ordinance

**City of Hoschton**

**ORDINANCE NO. O-24-01**

**AN ORDINANCE TO ADD SECTION 1-113 TO THE CODE OF ORDINANCES OF THE CITY OF HOSCHTON AS SET FORTH BELOW; TO REPEAL CONFLICTING ORDINANCES; TO PROVIDE FOR SEVERABILITY; TO PROVIDE FOR CODIFICATION; TO PROVIDE FOR AN EFFECTIVE DATE; AND FOR OTHER PURPOSES.**

WHEREAS, the Mayor and Councilmembers desire to add the Code section as more specifically described herein in order to allow for the disposition of real property under Georgia law.

NOW THEREFORE THE CITY COUNCIL OF THE CITY OF HOSCHTON HEREBY ORDAINS as follows:

**SECTION I.**

Section 1-113 is hereby added to the Hoschton City by adding the following:

**Sec. 1-113. - Disposition of parcels of narrow strips of land; terms and conditions of purchase.**

- (a) As set forth in O.C.G.A. § 36-37-6(g), as hereinafter amended, the city may sell and convey parcels of narrow strips of land, so shaped or so small as to be incapable of being used independently as zoned or under applicable subdivision or other development ordinances, or as streets, whether owned in fee or used by easement, to abutting property owners where such sales and conveyances facilitate the enjoyment of the highest and best use of the abutting owner's property without first submitting the sale or conveyance to the process of an auction or the solicitation of sealed bids; provided, however, that each abutting property owner shall be notified of the availability of the property and shall have the opportunity to purchase said property under such terms and conditions as set out by ordinance.
- (b) If city-owned property is identified for potential sale or conveyance pursuant to subsection 1-113(a), the city, through the city manager or the city manager's designee, may make the following determinations in writing:
  - (1) That the real property sought to be sold or conveyed meets the criteria set forth in subsection 1-113(a) and state law, as amended; and
  - (2) The reasonable fair market value of the property, based upon an appraisal conducted by a licensed real estate appraiser within one year of making such determination.
- (c) Upon completion of the determinations set forth in subsection 1-113(b), the city may notify in writing by certified mail or statutory overnight delivery as defined in O.C.G.A. § 9-10-12, as hereinafter amended, each abutting property owner of the availability of the property for purchase and present the opportunity to purchase the property at its fair market value, as determined by the city manager or the city manager's designee under subsection 1-113(b). The notice shall further provide that the abutting property owner has 30 days from the date of the notice to express a desire in writing to purchase the property at the fair market value stated in the notice. The abutting property owner's written response expressing the desire to purchase shall be delivered to the city representative identified in the written notice to the abutting property owner.

- (d) If the city receives only one response from an abutting property owner expressing a desire to purchase the property, then a recommendation may be presented by the city manager or the city manager's designee to the city council for its consideration and approval to sell such property to the abutting property owner for the fair market value set forth in the notice to the abutting property owner.
- (e) If the city receives a response from more than one abutting property owner expressing a desire to purchase the property, then a recommendation may be presented by the city manager or the city manager's designee to the city council for its consideration and approval as to the disposition of property that facilitates the enjoyment of the highest and best use of the abutting owner's property.
- (f) In the event the city receives no response from any abutting property owner, then the city may consider conveying the property in the best interest of the city, negotiating the sale or conveyance with one or more abutting property owners, or selling the property via a competitive bidding process as set forth in O.C.G.A. § 36-37-6(a), as hereinafter amended.
- (g) Nothing in this section shall obligate the city in any manner to sell and/or convey any property identified hereunder.

## **SECTION II.**

All ordinances and parts of ordinances in conflict herewith are hereby repealed.

## **SECTION III.**

If any portion of this ordinance shall be held to be invalid or unconstitutional, such invalidity or unconstitutionality shall not affect or impair the remaining portions unless it clearly appears that such other parts are wholly and necessarily dependent upon the part held to be invalid or unconstitutional.

**SECTION IV.**

The effective date of this ordinance shall be upon passage by the City Council.

Adopted this \_\_\_\_\_ day of \_\_\_\_\_, 2024.

---

Debbie Martin, Mayor

This is to certify that I am City Clerk of the City of Hoschton. As such, I keep its official records, including its minutes. In that capacity, my signature below certifies this ordinance was adopted as stated and will be recorded in the official minutes.

ATTEST:

---

City Clerk

APPROVED AS TO FORM

---

Abbott S. Hayes, Jr., City Attorney  
4882-7724-5594, v. 2

# NEW BUSINESS

## ITEM #4

2024 Recommendation of Council Meeting  
Dates and Time

# City of Hoschton 2024 Meeting Schedule

- CITY COUNCIL -		
WORK SESSION (6:00pm)	REGULAR MEETING (6:00pm)	APPLICATION SUBMITTAL DEADLINE
January 11 <sup>th</sup>	January 15 <sup>th</sup>	December 1 <sup>st</sup>
February 8 <sup>th</sup>	February 27 <sup>th</sup>	January 5 <sup>th</sup>
March 14 <sup>th</sup>	March 26 <sup>th</sup>	February 2 <sup>nd</sup>
April 11 <sup>th</sup>	April 23 <sup>rd</sup>	March 1 <sup>st</sup>
May 9 <sup>th</sup>	May 28 <sup>th</sup>	April 5 <sup>th</sup>
June 13 <sup>th</sup>	June 18 <sup>th</sup>	May 3 <sup>rd</sup>
July 11 <sup>th</sup>	July 23 <sup>rd</sup>	June 7 <sup>th</sup>
August 8 <sup>th</sup>	August 27 <sup>th</sup>	July 5 <sup>th</sup>
September 12 <sup>th</sup>	September 24 <sup>th</sup>	August 2 <sup>nd</sup>
October 10 <sup>th</sup>	October 22 <sup>nd</sup>	September 6 <sup>th</sup>
November 14 <sup>th</sup>	November 26 <sup>th</sup>	October 4 <sup>th</sup>
December 12 <sup>th</sup>	December 17 <sup>th</sup>	November 1 <sup>st</sup>
January 9 <sup>th</sup>	January 28 <sup>th</sup>	December 6 <sup>th</sup>

DOWNTOWN DEVELOPMENT AUTHORITY (6:00pm)
January 8 <sup>th</sup>
February 12 <sup>th</sup>
March 11 <sup>th</sup>
April 8 <sup>th</sup>
May 13 <sup>th</sup>
June 10 <sup>th</sup>
July 8 <sup>th</sup>
August 12 <sup>th</sup>
September 9 <sup>th</sup>
October 14 <sup>th</sup>
November 11 <sup>th</sup>
December 9 <sup>th</sup>
January 13 <sup>th</sup>

All meetings are held at

**Hoschton Community Center**  
**65 City Square**  
**Hoschton, GA 30548**



HISTORIC PRESERVATION COMMITTEE (3:00pm)
January 25 <sup>th</sup>
February 22 <sup>nd</sup>
March 28 <sup>th</sup>
April 25 <sup>th</sup>
May 23 <sup>rd</sup>
June 27 <sup>th</sup>
July 25 <sup>th</sup>
August 22 <sup>nd</sup>
September 26 <sup>th</sup>
October 24 <sup>th</sup>
November 21 <sup>st</sup>
December 19 <sup>th</sup>
January 23 <sup>rd</sup>

# NEW BUSINESS

## ITEM #5

2024 Recommendation of DDA Meeting  
Dates and Time

# City of Hoschton 2024 Meeting Schedule

## - CITY COUNCIL -

WORK SESSION (6:00pm)	REGULAR MEETING (6:00pm)	APPLICATION SUBMITTAL DEADLINE
January 11 <sup>th</sup>	January 15 <sup>th</sup>	December 1 <sup>st</sup>
February 8 <sup>th</sup>	February 27 <sup>th</sup>	January 5 <sup>th</sup>
March 14 <sup>th</sup>	March 26 <sup>th</sup>	February 2 <sup>nd</sup>
April 11 <sup>th</sup>	April 23 <sup>rd</sup>	March 1 <sup>st</sup>
May 9 <sup>th</sup>	May 28 <sup>th</sup>	April 5 <sup>th</sup>
June 13 <sup>th</sup>	June 18 <sup>th</sup>	May 3 <sup>rd</sup>
July 11 <sup>th</sup>	July 23 <sup>rd</sup>	June 7 <sup>th</sup>
August 8 <sup>th</sup>	August 27 <sup>th</sup>	July 5 <sup>th</sup>
September 12 <sup>th</sup>	September 24 <sup>th</sup>	August 2 <sup>nd</sup>
October 10 <sup>th</sup>	October 22 <sup>nd</sup>	September 6 <sup>th</sup>
November 14 <sup>th</sup>	November 26 <sup>th</sup>	October 4 <sup>th</sup>
December 12 <sup>th</sup>	December 17 <sup>th</sup>	November 1 <sup>st</sup>
January 9 <sup>th</sup>	January 28 <sup>th</sup>	December 6 <sup>th</sup>

### DOWNTOWN DEVELOPMENT AUTHORITY

(6:00pm)

January 8 <sup>th</sup>
February 12 <sup>th</sup>
March 11 <sup>th</sup>
April 8 <sup>th</sup>
May 13 <sup>th</sup>
June 10 <sup>th</sup>
July 8 <sup>th</sup>
August 12 <sup>th</sup>
September 9 <sup>th</sup>
October 14 <sup>th</sup>
November 11 <sup>th</sup>
December 9 <sup>th</sup>
January 13 <sup>th</sup>

### HISTORIC PRESERVATION COMMITTEE

(3:00pm)

January 25 <sup>th</sup>
February 22 <sup>nd</sup>
March 28 <sup>th</sup>
April 25 <sup>th</sup>
May 23 <sup>rd</sup>
June 27 <sup>th</sup>
July 25 <sup>th</sup>
August 22 <sup>nd</sup>
September 26 <sup>th</sup>
October 24 <sup>th</sup>
November 21 <sup>st</sup>
December 19 <sup>th</sup>
January 23 <sup>rd</sup>

All meetings are held at

**Hoschton Community Center**  
**65 City Square**  
**Hoschton, GA 30548**





# NEW BUSINESS

## ITEM #6

2024 Recommendation of  
Historic Preservation Committee  
Meeting Dates and Time

# City of Hoschton 2024 Meeting Schedule

- CITY COUNCIL -		
WORK SESSION (6:00pm)	REGULAR MEETING (6:00pm)	APPLICATION SUBMITTAL DEADLINE
January 11 <sup>th</sup>	January 15 <sup>th</sup>	December 1 <sup>st</sup>
February 8 <sup>th</sup>	February 27 <sup>th</sup>	January 5 <sup>th</sup>
March 14 <sup>th</sup>	March 26 <sup>th</sup>	February 2 <sup>nd</sup>
April 11 <sup>th</sup>	April 23 <sup>rd</sup>	March 1 <sup>st</sup>
May 9 <sup>th</sup>	May 28 <sup>th</sup>	April 5 <sup>th</sup>
June 13 <sup>th</sup>	June 18 <sup>th</sup>	May 3 <sup>rd</sup>
July 11 <sup>th</sup>	July 23 <sup>rd</sup>	June 7 <sup>th</sup>
August 8 <sup>th</sup>	August 27 <sup>th</sup>	July 5 <sup>th</sup>
September 12 <sup>th</sup>	September 24 <sup>th</sup>	August 2 <sup>nd</sup>
October 10 <sup>th</sup>	October 22 <sup>nd</sup>	September 6 <sup>th</sup>
November 14 <sup>th</sup>	November 26 <sup>th</sup>	October 4 <sup>th</sup>
December 12 <sup>th</sup>	December 17 <sup>th</sup>	November 1 <sup>st</sup>
January 9 <sup>th</sup>	January 28 <sup>th</sup>	December 6 <sup>th</sup>

DOWNTOWN DEVELOPMENT AUTHORITY (6:00pm)
January 8 <sup>th</sup>
February 12 <sup>th</sup>
March 11 <sup>th</sup>
April 8 <sup>th</sup>
May 13 <sup>th</sup>
June 10 <sup>th</sup>
July 8 <sup>th</sup>
August 12 <sup>th</sup>
September 9 <sup>th</sup>
October 14 <sup>th</sup>
November 11 <sup>th</sup>
December 9 <sup>th</sup>
January 13 <sup>th</sup>

HISTORIC PRESERVATION COMMITTEE (3:00pm)
January 25 <sup>th</sup>
February 22 <sup>nd</sup>
March 28 <sup>th</sup>
April 25 <sup>th</sup>
May 23 <sup>rd</sup>
June 27 <sup>th</sup>
July 25 <sup>th</sup>
August 22 <sup>nd</sup>
September 26 <sup>th</sup>
October 24 <sup>th</sup>
November 21 <sup>st</sup>
December 19 <sup>th</sup>
January 23 <sup>rd</sup>

All meetings are held at  
**Hoschton Community Center**  
**65 City Square**  
**Hoschton, GA 30548**



# NEW BUSINESS

## ITEM #7

2024 Municipal Court Dates and Time

Judge  
Honorable Ben Green

Solicitor  
Ms. Amy Carter



Court Clerk  
Ms. Sheryl Davis

## 2024 MUNICIPAL COURT DATES

February 15, 2024

April 18, 2024

June 20, 2024

August 15, 2024

October 17, 2024

December 19, 2024

### Location:

Hoschton Community Center  
65 City Square  
Hoschton, GA 30548

# NEW BUSINESS

## ITEM #8

Recommendation to appoint new Downtown  
Development Authority Board Members

(no documentation)

# NEW BUSINESS

## ITEM #9

Recommendation of Council Committees

(no documentation)

# NEW BUSINESS

## ITEM #10

Recommendation of Mayor Pro Tem  
(no documentation)

# NEW BUSINESS

## ITEM #11

Recommendation of Ethics Board Members

(no documentation)



# NEW BUSINESS

## ITEM #12

Public Works Building construction estimate  
from Garland Contractors, Inc.



**Contractors, Inc.**

PO Box 370  
Bogart, GA 30622

**General Contractors**

OFF (770)725-9000  
FAX (770)725-8900

## Hoschton Public Works Project

374 Cabin Dr, Hoschton GA 30548

### Budget Site & Building Estimate Summary

January 3, 2024

Based on preliminary drawings by DuSouth and Garland

1 Mobilization			\$ 2,500.00
2 Site - clearing, gravel pad, dumpster pad, concrete apron building pad grading, safety fence			\$ 91,700.00
3 Earthwork - grading			\$ 80,500.00
4 Erosion Control			\$ 28,500.00
5 Water - 1.5" PVC waterline - tap/meter by the owner		By owner	\$ -
6 Sanitary Sewer - does not include pump station		By owner	\$ -
7 Storm Sewer			\$ 8,500.00
8 Landscaping		allowance	\$ 15,000.00
9 Survey, layouts and as-builts			\$ 5,200.00
10 Pre-engineered building material			\$ 75,548.00
PEMB roof and wall insulation			\$ 6,700.00
Labor to erect PEMB			\$ 34,000.00
Building Details:			
58' x 66' x 21' high eave			
Design Loads - IBC 2018			
20 PSF live load, 108 MPH wind load			
Standard gutters & downspouts			
Roof material - 24 gauge standing seam galvalume			
Wall material - 26 gauge exposed fastener with standard finish			



**Contractors, Inc.**

PO Box 370  
Bogart, GA 30622

**General Contractors**

OFF (770)725-9000  
FAX (770)725-8900

11 Concrete - building footings and slab 6" concrete slab with 3,000 PSI concrete Pier estimated - to be confirmed with PEMB reactions		\$ 60,657.00
12 HVAC - restroom HVAC and warehouse heat Restroom exhaust fans, warehouse exhaust fans		\$ 12,000.00
13 Electrical - per plans No low voltage. No service lateral included.		\$ 35,000.00
14 Plumbing Sanitary waste and vent piping in schedule 40 PVC Provide and install floor drains in shop Provide and install one water heater Provide and install fixtures as shown on the plan		\$ 34,000.00
15 Overhead doors (4) 14' x 14' doors (3) 10' x 10' doors		\$ 36,420.00
16 Painting		\$ 2,500.00
17 Personel Doors		\$ 2,500.00
18 Fencing - allowance only for perimeter fencing if needed	Allowance	\$ 16,450.00
19 Office and bathrooms Framing, insulation and drywall		\$ 7,000.00
Restroom accessories		\$ 2,215.00
20 Architectural, structural and MEP Design Cost (No engineer stamp on MEP - by subcontractor)		\$ 15,000.00
21 Supervision, Travel, Tools, Equipment Temporary Toilet, Utilities		\$ 129,000.00
22 Insurance		\$ 9,600.00

# Garland

## Contractors, Inc.

PO Box 370  
Bogart, GA 30622

## General Contractors

OFF (770)725-9000  
FAX (770)725-8900

23 Testing and special inspections	Allowance	\$ 10,000.00
24 Final Clean Up		\$ 2,500.00
25 Permits & Fees		by owner
26 Payment and Performance Bond		\$ 15,905.00
<b>Total Building Cost:</b>		<b>\$ 738,895.00</b>
<b>G.C. Overhead - 6%</b>		<b>\$ 44,333.70</b>
<b>GC Profit - 4%</b>		<b>\$ 29,555.80</b>
		<b>\$ 812,784.50</b>

### NOTES

- 1 No building signage
- 2 No contingency money has been included.
- 3 No low voltage or security
- 4 No fire alarm system
- 5 No painting of exposed roof and wall steel structure
- 6 No interior liner panels
- 7 No pipe bollards
- 8 No shop equipment including racks, tools, lifts, etc.

**DUSOUTH**  
Land Surveying & Civil Contract  
2700 Howell Dr. Suite 100  
Office Phone: 706-330-1961  
Email: [gsouth@du-south.com](mailto:gsouth@du-south.com)  
Office: [www.du-south.com](http://www.du-south.com)

**Engineering Plans for:**  
**HOSCHTON PUBLIC WORKS**  
374 CABIN DRIVE  
HOSCHTON, GA 30548  
JACKSON COUNTY  
PARCEL: 120103R

**24 Hour Contact:**  
STEVEN CHRISTIAN  
404-606-9932  
[steven@gsouthconstruction.com](mailto:steven@gsouthconstruction.com)

**Prepared for:**  
**CITY OF HOSCHTON**  
1500 HOSCHTON AVENUE  
HOSCHTON, GA 30548  
STEVEN CHRISTIAN  
404-606-9932

CHANGES	DATE

**Date**  
11/14/2023

**Project Number**  
23-197

**Sheet Title**  
SITE PLAN

**Sheet Number**  
C3.0

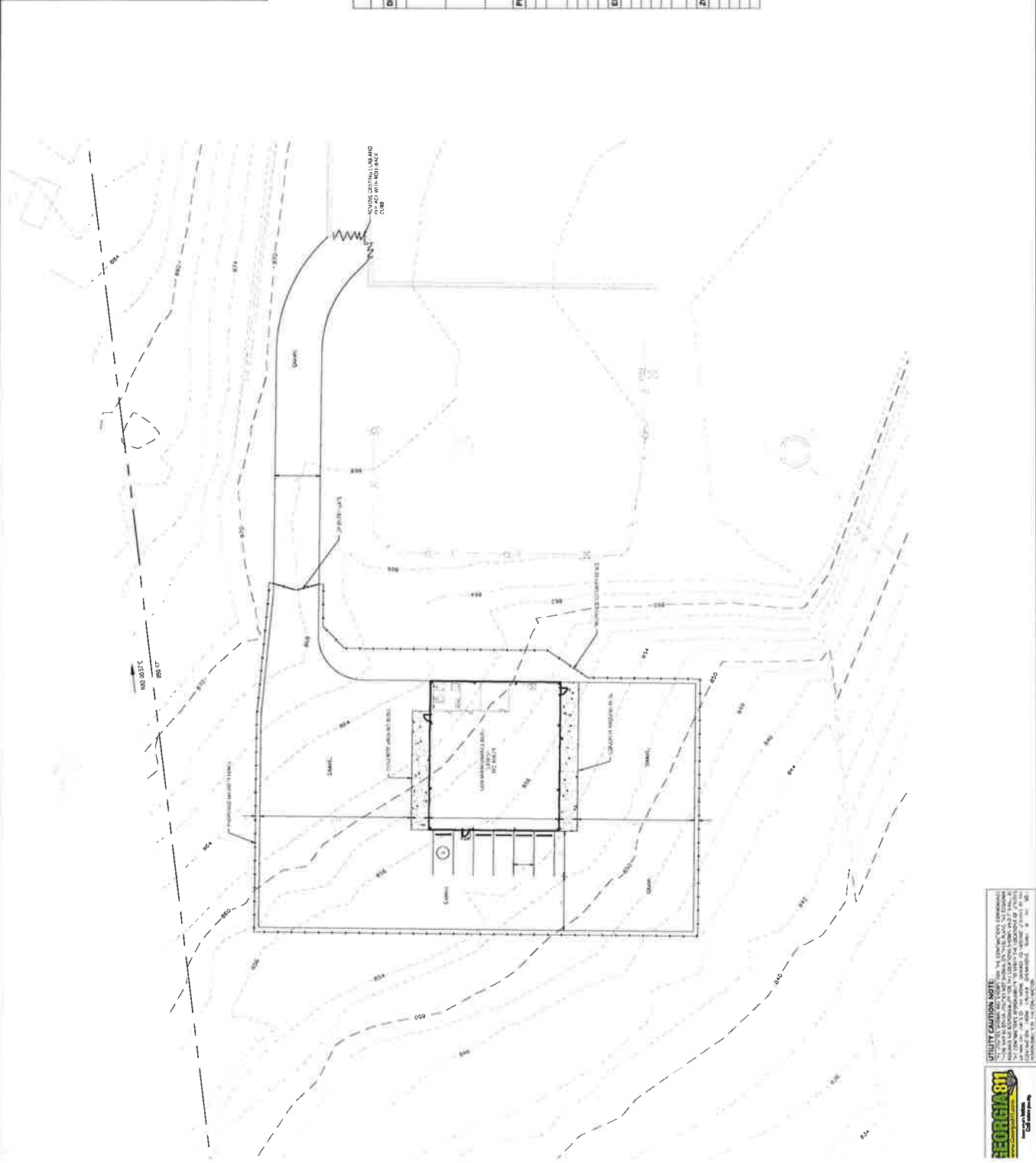

**UTILITY CAUTION NOTE**  
THE USER SHALL BE RESPONSIBLE FOR OBTAINING ALL NECESSARY PERMITS AND APPROVALS FROM ALL APPLICABLE AGENCIES AND UTILITIES. THE USER SHALL BE RESPONSIBLE FOR VERIFYING THE ACCURACY OF ALL UTILITIES SHOWN ON THIS PLAN. THE USER SHALL BE RESPONSIBLE FOR OBTAINING ALL NECESSARY PERMITS AND APPROVALS FROM ALL APPLICABLE AGENCIES AND UTILITIES. THE USER SHALL BE RESPONSIBLE FOR VERIFYING THE ACCURACY OF ALL UTILITIES SHOWN ON THIS PLAN. THE USER SHALL BE RESPONSIBLE FOR OBTAINING ALL NECESSARY PERMITS AND APPROVALS FROM ALL APPLICABLE AGENCIES AND UTILITIES. THE USER SHALL BE RESPONSIBLE FOR VERIFYING THE ACCURACY OF ALL UTILITIES SHOWN ON THIS PLAN.

**GRAPHIC SCALE**  
SCALE: 1" = 20'



**DUSOUTH**  
Land Surveying Civil Contract

27 Barrett Street, Wood  
Office Phone: 706.333.1561  
Email: dussouthsurveying@gmail.com  
Website: www.dussouthsurveying.com

**Engineering Plans for:**

**HOSCHTON PUBLIC WORKS**  
374 CABIN DRIVE  
HOSCHTON GA 30548  
JACKSON COUNTY  
PARCEL: 20.08R  
**24 Hour Contact:**  
STEVEN CHRISTIAN  
404-606-9592  
steven@hosaconstruction.com

**Prepared for:**

**CITY OF HOSCHTON**  
CITY SQUARE  
HOSCHTON GA 30548  
STEVEN CHRISTIAN  
404-606-9592

CHANGES	DATE

**Date**  
11/14/2023

**Project Number**  
23-197

**Sheet Title**  
GRADING &  
DRAINAGE PLAN

**Sheet Number**  
C4.0



**VICINITY MAP**  
1:400' TO SCALE

**GRADING NOTES**  
THE CONTRACTOR IS SPECIFICALLY CAUTIONED THAT THE LOCATION AND/OR ELEVATION OF EXISTING UTILITIES SHALL BE VERIFIED PRIOR TO ANY GRADING OPERATIONS. THE CONTRACTOR SHALL BE RESPONSIBLE FOR OBTAINING ALL NECESSARY PERMITS AND APPROVALS FROM THE CITY OF HOSCHTON AND THE JACKSON COUNTY BOARD OF SUPERVISORS PRIOR TO THE START OF ANY GRADING OPERATIONS. ALL EXISTING UTILITIES SHALL BE PROTECTED AND DEEPENED AS NECESSARY TO MAINTAIN THE PROPOSED GRADING. ALL NEW UTILITIES SHALL BE INSTALLED IN ACCORDANCE WITH THE CITY OF HOSCHTON AND JACKSON COUNTY ORDINANCES AND STANDARDS. ALL GRADING SHALL BE DONE IN ACCORDANCE WITH THE CITY OF HOSCHTON AND JACKSON COUNTY ORDINANCES AND STANDARDS. ALL GRADING SHALL BE DONE IN ACCORDANCE WITH THE CITY OF HOSCHTON AND JACKSON COUNTY ORDINANCES AND STANDARDS. ALL GRADING SHALL BE DONE IN ACCORDANCE WITH THE CITY OF HOSCHTON AND JACKSON COUNTY ORDINANCES AND STANDARDS.

THE CONTRACTOR SHALL BE RESPONSIBLE FOR OBTAINING ALL NECESSARY PERMITS AND APPROVALS FROM THE CITY OF HOSCHTON AND THE JACKSON COUNTY BOARD OF SUPERVISORS PRIOR TO THE START OF ANY GRADING OPERATIONS. ALL EXISTING UTILITIES SHALL BE PROTECTED AND DEEPENED AS NECESSARY TO MAINTAIN THE PROPOSED GRADING. ALL NEW UTILITIES SHALL BE INSTALLED IN ACCORDANCE WITH THE CITY OF HOSCHTON AND JACKSON COUNTY ORDINANCES AND STANDARDS. ALL GRADING SHALL BE DONE IN ACCORDANCE WITH THE CITY OF HOSCHTON AND JACKSON COUNTY ORDINANCES AND STANDARDS. ALL GRADING SHALL BE DONE IN ACCORDANCE WITH THE CITY OF HOSCHTON AND JACKSON COUNTY ORDINANCES AND STANDARDS.

THE CONTRACTOR SHALL BE RESPONSIBLE FOR OBTAINING ALL NECESSARY PERMITS AND APPROVALS FROM THE CITY OF HOSCHTON AND THE JACKSON COUNTY BOARD OF SUPERVISORS PRIOR TO THE START OF ANY GRADING OPERATIONS. ALL EXISTING UTILITIES SHALL BE PROTECTED AND DEEPENED AS NECESSARY TO MAINTAIN THE PROPOSED GRADING. ALL NEW UTILITIES SHALL BE INSTALLED IN ACCORDANCE WITH THE CITY OF HOSCHTON AND JACKSON COUNTY ORDINANCES AND STANDARDS. ALL GRADING SHALL BE DONE IN ACCORDANCE WITH THE CITY OF HOSCHTON AND JACKSON COUNTY ORDINANCES AND STANDARDS. ALL GRADING SHALL BE DONE IN ACCORDANCE WITH THE CITY OF HOSCHTON AND JACKSON COUNTY ORDINANCES AND STANDARDS.

THE CONTRACTOR SHALL BE RESPONSIBLE FOR OBTAINING ALL NECESSARY PERMITS AND APPROVALS FROM THE CITY OF HOSCHTON AND THE JACKSON COUNTY BOARD OF SUPERVISORS PRIOR TO THE START OF ANY GRADING OPERATIONS. ALL EXISTING UTILITIES SHALL BE PROTECTED AND DEEPENED AS NECESSARY TO MAINTAIN THE PROPOSED GRADING. ALL NEW UTILITIES SHALL BE INSTALLED IN ACCORDANCE WITH THE CITY OF HOSCHTON AND JACKSON COUNTY ORDINANCES AND STANDARDS. ALL GRADING SHALL BE DONE IN ACCORDANCE WITH THE CITY OF HOSCHTON AND JACKSON COUNTY ORDINANCES AND STANDARDS. ALL GRADING SHALL BE DONE IN ACCORDANCE WITH THE CITY OF HOSCHTON AND JACKSON COUNTY ORDINANCES AND STANDARDS.

THE CONTRACTOR SHALL BE RESPONSIBLE FOR OBTAINING ALL NECESSARY PERMITS AND APPROVALS FROM THE CITY OF HOSCHTON AND THE JACKSON COUNTY BOARD OF SUPERVISORS PRIOR TO THE START OF ANY GRADING OPERATIONS. ALL EXISTING UTILITIES SHALL BE PROTECTED AND DEEPENED AS NECESSARY TO MAINTAIN THE PROPOSED GRADING. ALL NEW UTILITIES SHALL BE INSTALLED IN ACCORDANCE WITH THE CITY OF HOSCHTON AND JACKSON COUNTY ORDINANCES AND STANDARDS. ALL GRADING SHALL BE DONE IN ACCORDANCE WITH THE CITY OF HOSCHTON AND JACKSON COUNTY ORDINANCES AND STANDARDS. ALL GRADING SHALL BE DONE IN ACCORDANCE WITH THE CITY OF HOSCHTON AND JACKSON COUNTY ORDINANCES AND STANDARDS.



**GRAPHIC SCALE**  
1" = 40'

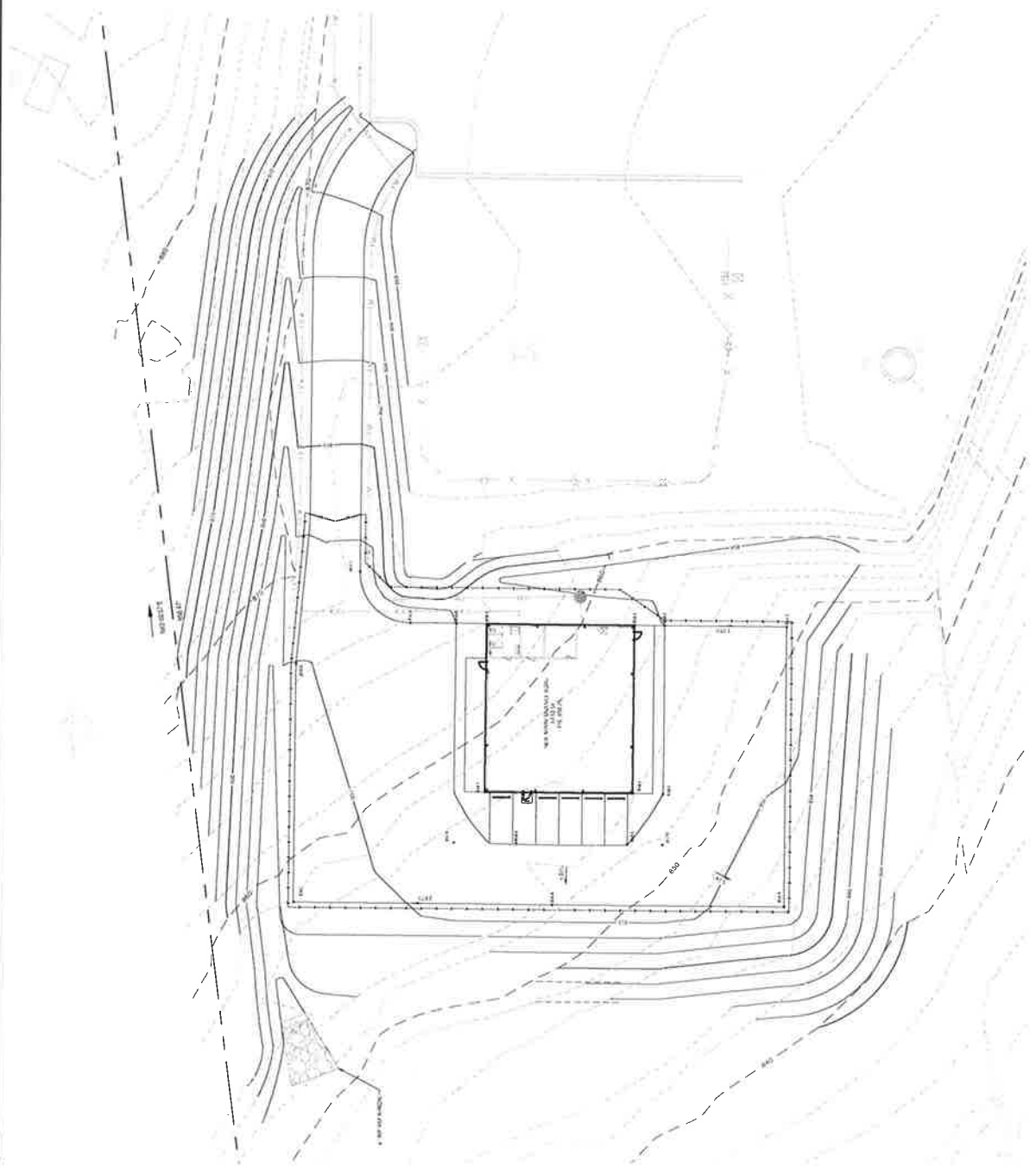

**CITY OF HOSCHTON GRADING AND DRAINAGE NOTES**  
1. THE CONTRACTOR SHALL BE RESPONSIBLE FOR OBTAINING ALL NECESSARY PERMITS AND APPROVALS FROM THE CITY OF HOSCHTON AND THE JACKSON COUNTY BOARD OF SUPERVISORS PRIOR TO THE START OF ANY GRADING OPERATIONS.  
2. ALL EXISTING UTILITIES SHALL BE PROTECTED AND DEEPENED AS NECESSARY TO MAINTAIN THE PROPOSED GRADING.  
3. ALL NEW UTILITIES SHALL BE INSTALLED IN ACCORDANCE WITH THE CITY OF HOSCHTON AND JACKSON COUNTY ORDINANCES AND STANDARDS.  
4. ALL GRADING SHALL BE DONE IN ACCORDANCE WITH THE CITY OF HOSCHTON AND JACKSON COUNTY ORDINANCES AND STANDARDS.

**UTILITY CAUTION NOTE**  
THE CONTRACTOR SHALL BE RESPONSIBLE FOR OBTAINING ALL NECESSARY PERMITS AND APPROVALS FROM THE CITY OF HOSCHTON AND THE JACKSON COUNTY BOARD OF SUPERVISORS PRIOR TO THE START OF ANY GRADING OPERATIONS. ALL EXISTING UTILITIES SHALL BE PROTECTED AND DEEPENED AS NECESSARY TO MAINTAIN THE PROPOSED GRADING. ALL NEW UTILITIES SHALL BE INSTALLED IN ACCORDANCE WITH THE CITY OF HOSCHTON AND JACKSON COUNTY ORDINANCES AND STANDARDS. ALL GRADING SHALL BE DONE IN ACCORDANCE WITH THE CITY OF HOSCHTON AND JACKSON COUNTY ORDINANCES AND STANDARDS.



NO. 1	DATE	REVISION
11/14/21		ISSUE FOR RFP

PUBLIC WORKS BUILDING		
FOR:	CITY OF HOSCHTON	
214 GAIN DRIVE HOSCHTON, GA 30548		
PROJECT NUMBER		
SHEET NUMBER		

FLOOR PLAN		
PROJECT TITLE		
SHEET NUMBER		
A1		

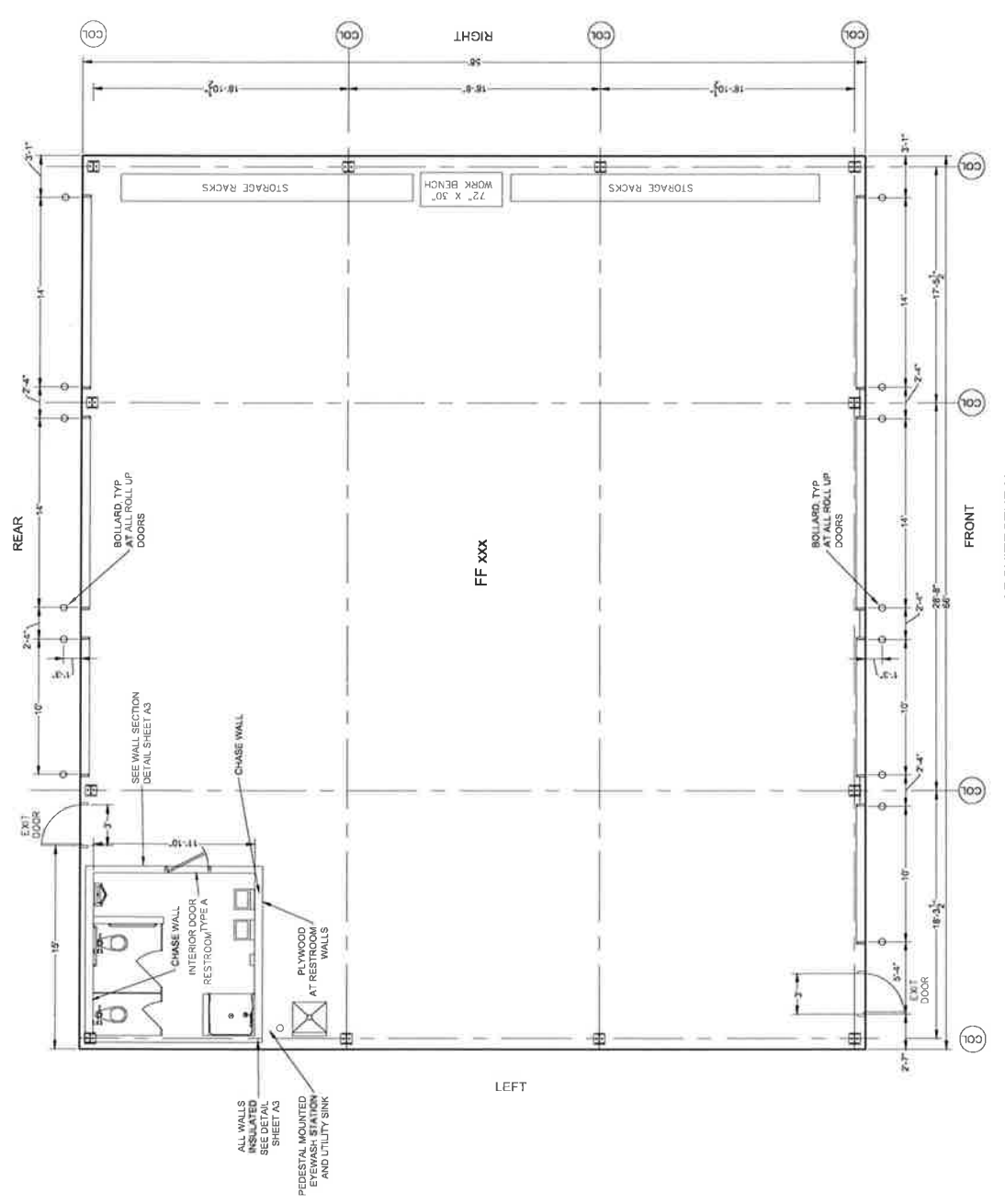

ARCHITECTURAL  
 PLAN VIEW  
 1/4" = 1'-0"

SEE SHEET A2 FOR ELEVATIONS AND SPECIFICATIONS

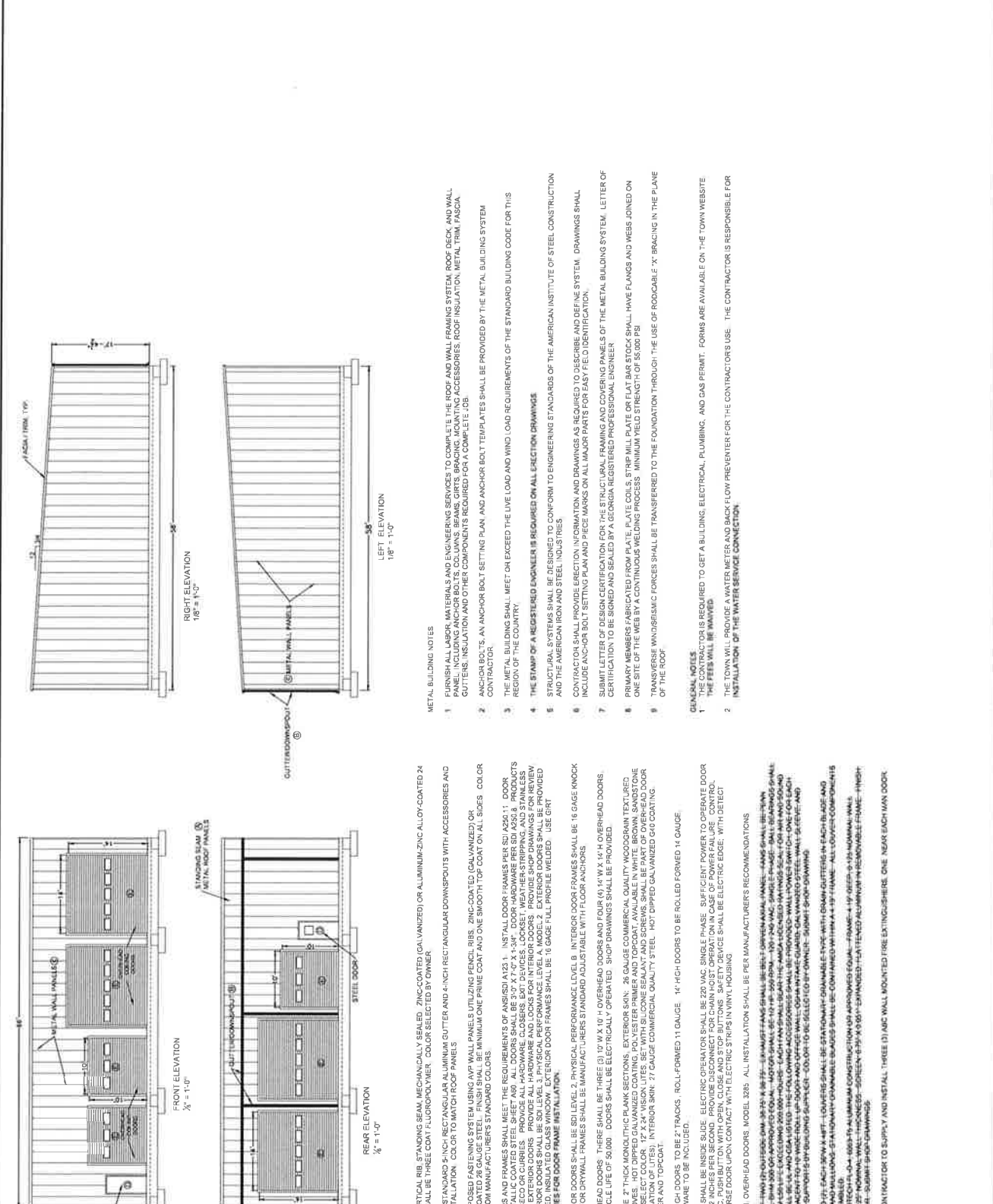

**METAL BUILDING NOTES**

1. FURNISH ALL LABOR, MATERIALS AND ENGINEERING SERVICES TO COMPLETE THE ROOF AND WALL FRAMING SYSTEM, ROOF DECK AND WALL PANEL, INCLUDING ANCHOR BOLTS, COLLARS, BRAMS, GIRTS, BRACING, MOUNTING ACCESSORIES, ROOF INSULATION, METAL TRIM, FASZIA, GUTTERS, INSULATION AND OTHER COMPONENTS REQUIRED FOR A COMPLETE JOB.
2. ANCHOR BOLTS, AN ANCHOR BOLT SETTING PLAN, AND ANCHOR BOLT TEMPLATES SHALL BE PROVIDED BY THE METAL BUILDINGS SYSTEM CONTRACTOR.
3. THE METAL BUILDINGS SHALL MEET OR EXCEED THE LIVE LOAD AND WIND LOAD REQUIREMENTS OF THE STANDARD BUILDING CODE FOR THIS REGION OF THE COUNTRY.
4. THE STAMP OF A REGISTERED ENGINEER IS REQUIRED ON ALL ERECTION DRAWINGS.
5. STRUCTURAL SYSTEMS SHALL BE DESIGNED TO CONFORM TO ENGINEERING STANDARDS OF THE AMERICAN INSTITUTE OF STEEL CONSTRUCTION AND THE AMERICAN IRON AND STEEL INSTITUTES.
6. CONTRACTOR SHALL PROVIDE ERECTION INFORMATION AND DRAWINGS AS REQUIRED TO DESCRIBE AND DEFINE SYSTEM. DRAWINGS SHALL INCLUDE ANCHOR BOLT SETTING PLAN AND PIECE MARKS ON ALL MAJOR PARTS FOR EASY FIELD IDENTIFICATION.
7. SUBMIT LETTER OF DESIGN CERTIFICATION FOR THE STRUCTURAL FRAMING AND COVERING PANELS OF THE METAL BUILDINGS SYSTEM. LETTER OF CERTIFICATION TO BE SIGNED AND SEALED BY A GEORGIA REGISTERED PROFESSIONAL ENGINEER.
8. PRIMARY MEMBERS FABRICATED FROM PLATE, PLATE COILS, STRIP MILL PLATE OR FLAT BAR STOCK SHALL HAVE FLANGES AND WEBS JOINED ON ONE SIDE OF THE WEB BY A CONTINUOUS WELDING PROCESS. MINIMUM YIELD STRENGTH OF 55,000 PSI.
9. TRANSVERSE WIND/SEISMIC FORCES SHALL BE TRANSFERRED TO THE FOUNDATION THROUGH THE USE OF ROD/CABLE "X" BRACING IN THE PLANE OF THE ROOF.

**GENERAL NOTES**

1. THE CONTRACTOR IS REQUIRED TO GET A BUILDING, ELECTRICAL, PLUMBING, AND GAS PERMIT. FORMS ARE AVAILABLE ON THE TOWN WEBSITE. THE FEES WILL BE MAILED.
  2. THE TOWN WILL PROVIDE A WATER METER AND BACK FLOW PREVENTER FOR THE CONTRACTORS USE. THE CONTRACTOR IS RESPONSIBLE FOR INSTALLATION OF THE WATER SERVICE CONNECTION.
- GENERAL BUILDING NOTES:**
- A. METAL ROOF PANELS: VERTICAL RIB, STANDING SEAM, MECHANICALLY SEALED, ZINC-COATED (GALVANIZED) OR ALUMINUM-ZINC ALLOY-COATED 24 GAUGE STEEL, FINISH SHALL BE THREE COAT FLUOROPOLYMER, COLOR SELECTED BY OWNER.
  - B. METAL BUILDING MANUF. STANDARD 5-INCH RECTANGULAR ALUMINUM GUTTER AND 4-INCH RECTANGULAR DOWNSPOUTS WITH ACCESSORIES AND TRIM FOR COMPLETE INSTALLATION. COLOR TO MATCH ROOF PANELS.
  - C. METAL WALL PANELS: EXPOSED FASTENING SYSTEM USING AWP WALL PANELS UTILIZING PENCIL RIBS. ZINC-COATED (GALVANIZED) OR ALUMINUM-ZINC ALLOY-COATED 26 GAUGE STEEL. FINISH SHALL BE MINIMUM ONE PRIME COAT AND ONE SMOOTH TOP COAT ON ALL SIDES. COLOR SELECTED BY OWNER FROM MANUFACTURER'S STANDARD COLORS.
  - D. EXTERIOR DOORS: DOORS AND FRAMES SHALL MEET THE REQUIREMENTS OF ANISI/ASTM 123.1. INSTALL DOOR FRAMES PER S21 A250.11. DOOR FRAMES SHALL HAVE METALLIC COATED STEEL SHEET AND ALL DOORS SHALL BE 3'-0" X 7'-0" X 1'-3/4". DOOR HARDWARE PER S21 A250.8. PRODUCTS SHALL BE THE SAME AS SHOWN ON THE DRAWINGS. PROVIDE ALL HARDWARE AND DOORS FOR INTERIOR DOORS. PROVIDE SHOP DRAWINGS FOR REVIEW EXTERIOR DOORS. EXTERIOR DOORS SHALL BE 30 LEVEL 3, PHYSICAL PERFORMANCE LEVEL A, MODEL 2. EXTERIOR DOORS SHALL BE PROVIDED WITH A 1/8" X 1/8" TEMPERED INSULATED GLASS WINDOW. EXTERIOR DOOR FRAMES SHALL BE 16 GAUGE FULL PROFILE WELDED. USE GIRT ANCHORS AND BRACKETS FOR EXTERIOR DOOR FRAMES PER MANUF. INST.
  - E. INTERIOR DOORS: INTERIOR DOORS SHALL BE 30 LEVEL 2, PHYSICAL PERFORMANCE LEVEL B. INTERIOR DOOR FRAMES SHALL BE 16 GAUGE KNOCK DOWN WALL ANCHORS FOR DOOR WALL FRAMES SHALL BE MANUFACTURERS STANDARD ADJUSTABLE WITH FLOOR ANCHORS.
  - F. STEEL SECTIONAL OVERHEAD DOORS: THERE SHALL BE THREE (3) 10' X 10' H OVERHEAD DOORS AND FOUR (4) 14' X 14' H OVERHEAD DOORS. DOORS SHALL HAVE A CYCLE LIFE OF 50,000. DOORS SHALL BE ELECTRICALLY OPERATED. SHOP DRAWINGS SHALL BE PROVIDED. DOOR SECTIONS SHALL BE 2" THICK MONOLITHIC PLANK SECTIONS. EXTERIOR SKIN: 26 GAUGE COMMERCIAL QUALITY WOODGRAIN TEXTURED STEEL WITH MICRO-GRANULES. HOT DIPPER GALVANIZED COATING. POLYESTER PRIMER AND TOPCOAT. AVAILABLE IN WHITE, BROWN, SANDSTONE OR ANY COLOR MATCH TO EXISTING BUILDING COLOR. INTERIOR SKIN: 22 GAUGE COMMERCIAL QUALITY STEEL, HOT DIPPER GALVANIZED COATING. WHITE POLYESTER PRIMER AND TOPCOAT.
  - G. DOOR TRACKS FOR 10' HIGH DOORS TO BE 2" TRACKS, ROLL-FORMED 11 GAUGE. 14" HIGH DOORS TO BE ROLLED FORMED 14 GAUGE. ALL INSTALLATION HARDWARE TO BE INCLUDED.
  - H. OVERHEAD DOOR LOCKS SHALL BE INSIDE SLIDE. ELECTRIC OPERATOR SHALL BE 220 VAC, SINGLE PHASE. SUFFICIENT POWER TO OPERATE DOOR AT AVERAGE SPEED OF 12 INCHES PER SECOND. PROVIDE DISCONNECT FOR CHAIN HOST OPERATION IN CASE OF POWER FAILURE. CONTROL STATION SHALL BE 24 VDC, PUSH BUTTON WITH OPEN, CLOSE AND STOP BUTTONS. SAFETY DEVICE SHALL BE ELECTRIC EDGE, WITH DETECT, OBSTRUCTION AND REVERSE FOR UPON CONTACT WITH ELECTRIC STRIPS IN WIND HOUSING.
  - I. DOORS SHALL BE BY CH 1. OVERHEAD DOORS, MODEL 3285. ALL INSTALLATION SHALL BE PER MANUFACTURERS RECOMMENDATIONS.
  - J. GENERAL NOTE: TOTAL OF TWO (2) DOORS: ONE (1) 10' X 10' H OVERHEAD DOOR SHALL BE BY CH 1. OVERHEAD DOOR. THE OTHER (1) 14' X 14' H OVERHEAD DOOR SHALL BE BY CH 1. OVERHEAD DOOR. THE OTHER (1) 14' X 14' H OVERHEAD DOOR SHALL BE BY CH 1. OVERHEAD DOOR.
  - K. FIRE EXTINGUISHERS: CONTRACTOR TO SUPPLY AND INSTALL THREE (3) (ABC) WALL MOUNTED FIRE EXTINGUISHERS, ONE NEAR EACH MAIN DOOR.



QTY	TYPE	DOOR SCHEDULE				REMARKS
		DOOR	FRAME	FINISH	TYPE	
2	D	3'-2 1/2" x 6'-0"	H.M.	PAINTED	H.M.	EXTENDING DOOR CLOSER, THRESHOLD, WEATHERBANDING LOCK, WEATHERBANDING LOCK.
1	A	3'-0" x 7'-0"	H.M.	PAINTED	H.M.	INTERIOR DOOR, PASSAGE LEVER, CLOSER, KICKPLATE, LOCK

- DIV 08 FINISH-HARDWARE REFERENCES**
- AMERICAN NATIONAL STANDARD INSTITUTE (ANSI)
  - DOOR AND HARDWARE INSTITUTE (DHI)
  - FACTORY MUTUAL (FM)
  - NATIONAL FIRE PROTECTION ASSOCIATION (NFPA)
  - UNDERWRITERS LABORATORIES, INC. (UL)
  - WARNOCK HERSEY
  - AMERICANS WITH DISABILITIES ACT (ADA)
- DIV 08 STEEL DOORS AND FRAMES**
- DOORS AND FRAMES SHALL MEET THE REQUIREMENTS OF ANSISDA A123.1
  - FIRE RATED DOORS SHALL BE IN COMPLIANCE WITH NFPA 80, ASTM 152, AND UL 10C.
  - PRODUCTS SHALL BE THOSE MANUFACTURED BY STEELCRAFT, CECCO OR CURRIES.
  - EXTERIOR DOOR SHALL BE SDI LEVEL 3, PHYSICAL. INTERIOR DOOR SHALL BE SDI LEVEL 2, PHYSICAL.
  - PERFORMANCE B, MODEL 1, INTERIOR DOOR FRAMES PER SDI A250.11.
  - INSTALL DOOR FRAMES PER A250.11
  - LOCATE DOOR HARDWARE PER SDI A250.8
  - DOOR FRAMES SHALL HAVE METALLIC COATED STEEL SHEET AND FLAT, T-SHAPED ANCHOR NOT LESS THAN 10" WIDE 24" LONG, PROVIDE ONE ANCHOR PER 24" OF JAMB HEIGHT.
  - WALL ANCHORS FOR DRYWALL FRAMES SHALL BE MANUFACTURED STANDARD ADJUSTABLE WITH FLOOR ANCHORS.

- BUILDING INSULATION**
- SUBMIT PRODUCT DATA FOR EACH TYPE OF INSULATION. BLANKET INSULATION SHALL MEET ASTM C981, C614 AND C104
  - CLOSED CELL FOAM SHALL MEET CERTAIN REQUIREMENTS
  - CELL FOAM SPECIFICATIONS AND INSTALL REQUIREMENTS
- INSULATION SCHEDULE:**
- METAL BUILDING WALLS AND ROOF: FLEXIBLE BLANKET GLASS FIBER TYPE, FACED WITH WHITE VINYL, UL FLAME SPREAD CLASSIFICATION 1-1/2 IN. EXPOSED INSULATION SHALL BE 2" WITH 1/2" INSULATION TOWARDS THE CONDITIONED SPACE. HOLD IN PLACE WITH WITH INSULATION SUPPORT SYSTEM.
  - ROOF: R-16 (5-1/4" THICKNESS)
  - GYPSUM WALLS (NOT AGAINST BUILDING) AND RAFTERS ABOVE BATHROOM, OFFICE, AND STORAGE ROOM - R-10 (3-3/8" THICKNESS) FACE NOT REQUIRED
  - SPRAY FOAM ALTERNATE
  - EXPOSED METAL BUILDING WALLS: 2" CLOSED CELL FOAM
  - METAL BUILDING EXPOSED ROOF LINE: 3" CLOSED CELL FOAM
  - PAINT DB315 IGNITION BARRIER TO ALL EXPOSED
  - FOAM INSULATION ON METAL WALLS AND ROOF LINE
- PAINTING**
- PAINT SYSTEMS SHALL BE PER THE MASTERS PAINTERS INSTITUTE (MPI) ARCHITECTURAL PAINTING SPECIFICATION MANUAL AND SHALL BE PREMIUM GRADE. SURFACES TO RECEIVE PAINT SHALL BE PREPARED IN ACCORDANCE WITH THE MANUFACTURERS RECOMMENDATIONS.
  - PAINT SCHEDULE:**  
SUBSTRATE TYPE MPI SYSTEM  
GYPSUM BOARD LAYTEX MPI INT 9.2A  
GALVANIZED METAL LATEX MPI INT 5.3A  
WOOD (STAIN) LATEX MPI INT 6.4A  
WOOD (STAIN) MPI INT 6.3D  
SUBMIT 8 1/2" X 11" PAINT SAMPLES SHOWING COLOR AND FINISH OF EACH PAINT
  - DIV 61 ROUGH CARPENTRY:**  
1. AMERICAN WOOD PRESERVERS ASSOCIATION (AWPA)  
2. DOUGLAS FIRE PROTECTION ASSOCIATION (DFPA)  
3. NATIONAL FIRE PROTECTION ASSOCIATION (NFPA)

**A. LUMBER GRADING/MATERIAL:**  
A.1 DOUGLAS FIR - STANDARD GRADING AND DRESSING RULES, NO. 17  
WEST COAST LUMBER INSPECTION BUREAU.  
A.2 FLYING WOODS - PRODUCT STANDARDS (LATEST EDITION), GRADE 1, 2, 3, 4, 5, 6, 7, 8, 9, 10, 11, 12, 13, 14, 15, 16, 17, 18, 19, 20, 21, 22, 23, 24, 25, 26, 27, 28, 29, 30, 31, 32, 33, 34, 35, 36, 37, 38, 39, 40, 41, 42, 43, 44, 45, 46, 47, 48, 49, 50, 51, 52, 53, 54, 55, 56, 57, 58, 59, 60, 61, 62, 63, 64, 65, 66, 67, 68, 69, 70, 71, 72, 73, 74, 75, 76, 77, 78, 79, 80, 81, 82, 83, 84, 85, 86, 87, 88, 89, 90, 91, 92, 93, 94, 95, 96, 97, 98, 99, 100.  
B. FASTENING:  
B1 NAILS AND SPIKES: COMMON WIRE UNLESS OTHERWISE NOTED.  
a. NAILING OF WOOD MEMBERS SHALL CONFORM TO UNIFORM BUILDING CODE AND/OR AS INDICATED. BOX NAILS ARE NOT PERMITTED.  
b. SPACING AND SIZE OF NAILS TO BE SUCH THAT SPLITTING WILL NOT OCCUR. PROVIDE FASTENING NECESSARY TO PREVENT SPLITTING.  
B2 SCREWS: BRIGHT STEEL WOOD SCREWS.  
a. SCREWS ARE TO BE TURNED INTO PLACE, NOT DRIVEN. SELF-TAPPING WHERE REQUIRED FOR FASTENING TO METAL FRAMING.  
b. COUNTERSINK WHERE HEADS WILL INTERFERE OR AS REQUIRED.  
c. USE GALVANIZED OR CADMIUM PLATED SCREWS ON FASTENINGS EXPOSED TO WEATHER OR WHERE MEMBERS ARE BUILT-IN TO ROOFING.  
B3 BOLTS: STANDARD MILD STEEL, SQUARE OR HEX HEAD MACHINE BOLTS WITH SQUARE NUTS AND MALLEABLE IRON OR STEEL PLATE WASHERS, CONFORMING TO ASTM A307.  
a. TO BE INSTALLED IN DRILLED HOLES THE DIAMETER OF THE BOLT, 1/32 INCH TO 1/16 INCH OVER SIZE.  
b. BOLTING OF WOOD MEMBERS SHALL CONFORM TO CRC REQUIREMENTS AND AS CALLED FOR ON THE DRAWINGS.  
c. USE GALVANIZED BOLTS AND NUTS WHERE EXPOSED TO WEATHER OR WHERE MEMBERS ARE BUILT-IN TO ROOFING.

**C. WORKMANSHIP**  
C1 ROUGH CARPENTRY SHALL PRODUCE JOINTS TRUE, TIGHT, AND WELL NAILED WITH MEMBERS ASSEMBLED IN ACCORDANCE WITH THE DRAWINGS AND WITH PERTINENT CODES AND REGULATIONS.  
C2 INSTALL FRAMING IN STRICT ACCORDANCE WITH THE REQUIREMENTS OF CBC CHAPTER 23.

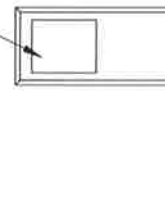
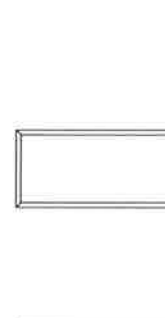

**DOOR TYPES**

(A) HOLLOW METAL

(D) HOLLOW METAL & GLASS

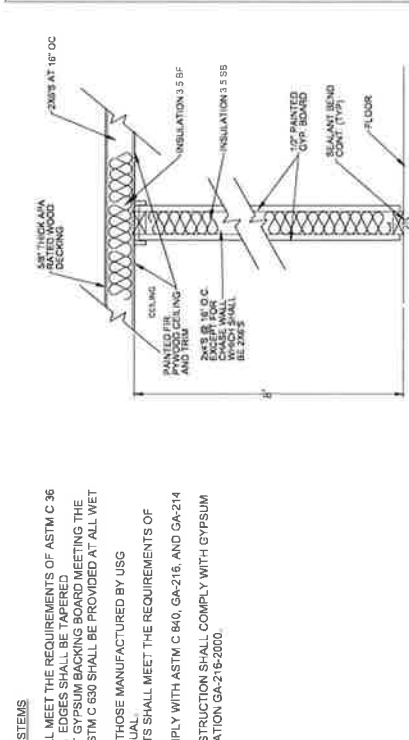
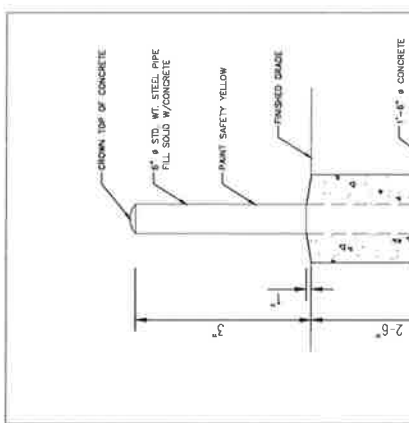

**WALL SECTION FOR ALL ROOMS**

**DETAIL NO. P-1**

DATE	11/19/23	ISSUED FOR PERMIT
PKS	DATE	SUBMITTAL NUMBER

**PUBLIC WORKS BUILDING**  
 CITY OF HOSCHTON  
 374 CABIN DRIVE  
 HOSCHTON, GA 30648

**FOUNDATION PLAN**  
 PROJECT NUMBER

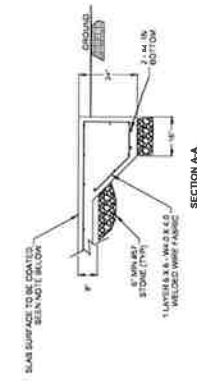
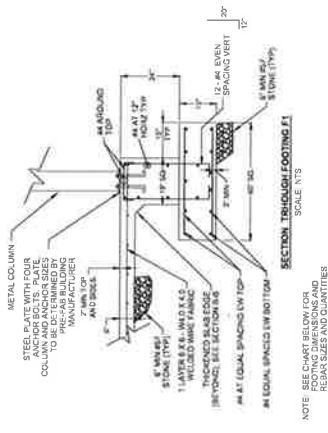

- SLAB SURFACE COATING**
1. SURFACE PREP: REFER TO SPCC-SP312.3 OR SPCC-312.3. CSP 1.3 SURFACES SHALL BE THOROUGHLY CLEANED AND DRIED. CONCRETE AND MORTAR MUST BE CURED AT LEAST 28 DAYS @ 50°F.
  2. FILL BUG HOLES, AIR POCKETS AND OTHER Voids WITH STEELSEAM PT919. PRIMER REQUIRED.
  3. HUMIDITY MAXIMUM OF 10 PERCENT.
  4. APPLICATION EQUIPMENT: CLEAN, TRACK-DEEP-TINE BASE. REQUIRES REDUCTION OF 5 PERCENT BY VOLUME.
- REDUCTION OF SOLVENT RESISTANT CORE:** REDUCTION - AS NEEDED UP TO 10 PERCENT BY VOLUME FOR PRIMER COAT ON NATURAL BRISTLE. REDUCTION - AS NEEDED UP TO 10 PERCENT BY VOLUME FOR PRIMER COAT ON SOLVENT RESISTANT CORE. REDUCTION - AS NEEDED UP TO 10 PERCENT BY VOLUME FOR PRIMER COAT ONLY.

**FOOTING DIMENSIONS AND REBAR SIZES AND QUANTITIES**

MARK. SIZE	THICKNESS	TOP BAR	BOTTOM BAR	DOVEL	DOVEL LENGTH
F1	15"	(8) #4 E.W.	(8) #4 E.W.	(12) #4	1'-8"
F2	15"	(8) #5 E.W.	(8) #5 E.W.	(12) #4	2'-8"

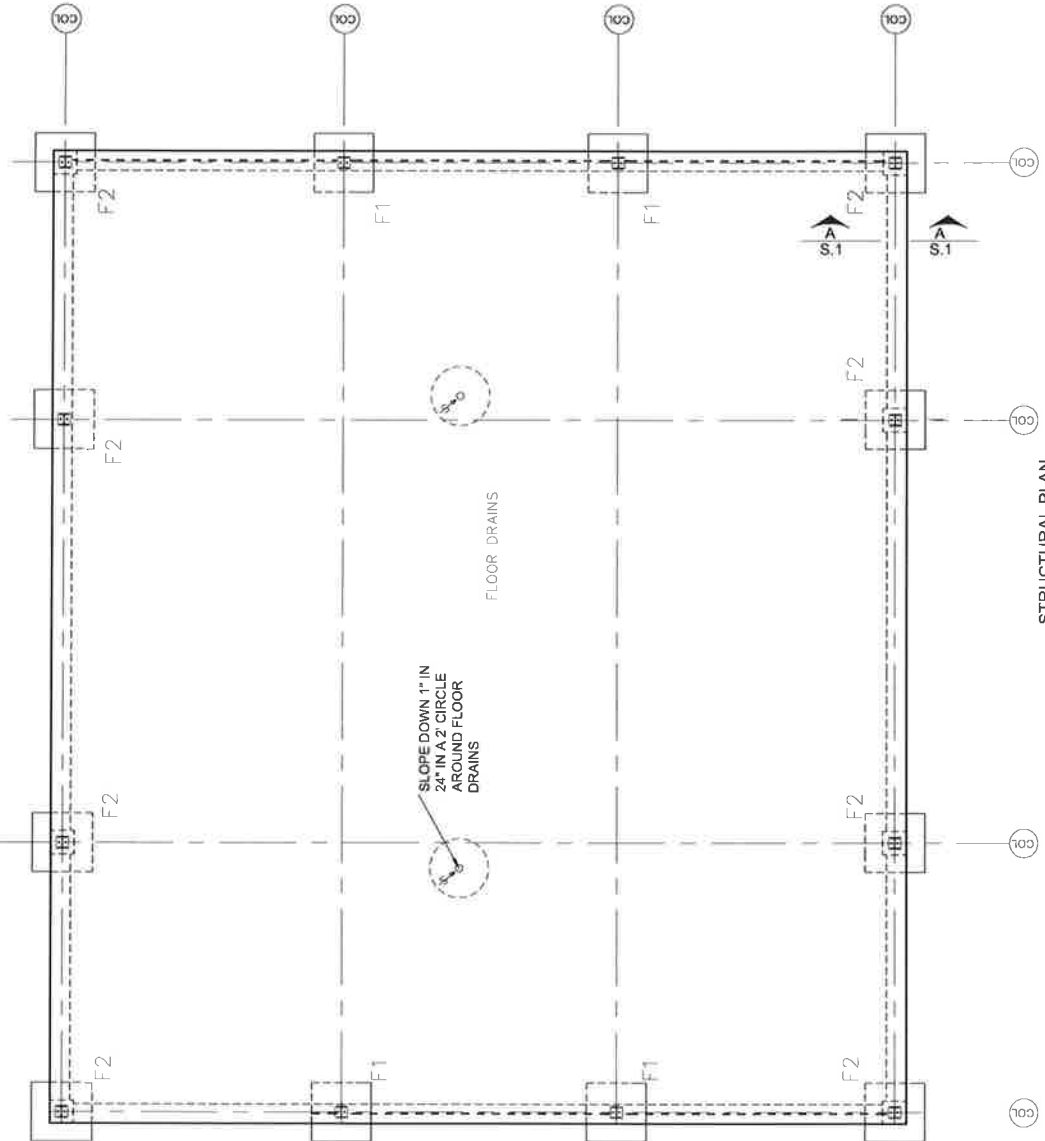

**STRUCTURAL PLAN**  
 1/4" = 1'-0"



- MECHANICAL NOTES & MODIFICATIONS**
1. THE SHOP AREA WILL UTILIZE COVERED VENTILATION AND MOTOR DRIVEN FANS FOR COOLING AND GAS-ELECTRIC WALL HEATERS FOR HEATING. WALL HEATERS SHALL BE HUNG A MINIMUM OF 7 FEET TO THE BOTTOM OF THE HEATER. THE HEATERS SHALL BE SIZED TO HEAT THE SHOP AREA. WALL HEATERS SHALL BE SIZED TO HEAT THE SHOP AREA. WALL HEATERS SHALL BE SIZED TO HEAT THE SHOP AREA. WALL HEATERS SHALL BE SIZED TO HEAT THE SHOP AREA.
  2. WALL HEATERS SPACED AROUND THE SHOP AREA. ONE WALL MOUNTED THERMOSTAT WALL CONTROL THE HEATERS. THE HEATERS SHALL BE SIZED TO HEAT THE SHOP AREA. WALL HEATERS SHALL BE SIZED TO HEAT THE SHOP AREA. WALL HEATERS SHALL BE SIZED TO HEAT THE SHOP AREA.
  3. SHOWN AS A GAS HEATER. THE CONTRACTOR SHALL VERIFY THE GAS PIPING AND SHALL BE RESPONSIBLE FOR THE GAS PIPING. THE CONTRACTOR SHALL VERIFY THE GAS PIPING AND SHALL BE RESPONSIBLE FOR THE GAS PIPING. THE CONTRACTOR SHALL VERIFY THE GAS PIPING AND SHALL BE RESPONSIBLE FOR THE GAS PIPING.
  4. ALL THERMOSTATS SHALL BE INSTALLED 5'0" HGT.
  5. ALL LOW VOLTAGE CONTROL WIRING SHALL BE UNDER THE CONTRACTOR'S ELECTRICAL JURISDICTION. ALL ELECTRICAL CONNECTIONS SHALL BE SUPPLIED WITH DISCONNECT (PROVIDED BY ELECTRICAL CONTRACTOR).
  6. ALL MECHANICAL EQUIPMENT WHICH HAVE ELECTRICAL CONNECTIONS SHALL BE SUPPLIED WITH DISCONNECT (PROVIDED BY ELECTRICAL CONTRACTOR).
  7. ALL MECHANICAL EQUIPMENT WHICH HAVE ELECTRICAL CONNECTIONS SHALL BE SUPPLIED WITH DISCONNECT (PROVIDED BY ELECTRICAL CONTRACTOR).

FANS							
MARK	SERVICE	TYPE	CFM	HQTS	HP	SP. IN. AME	REMARKS
EF-A	PUBLIC RR	CABINET	40	0.15	3/8	1.5	1.2

AIR HANDLING UNITS (TO BE COMPLETED BY CONTRACTOR)					
MARK	HEATING CAP	Cooling CAP	MAX. ELECTRICAL LOAD	UNIT WT. (LBS)	REMARKS
AHU-2	RESTROOM	220	220	720	

- ① DISCONNECT
- ② HEWSTAT
- ③ GAS HEATER

TANKLESS WATER HEATER SHALL BE SIZED FOR 3 GPM, 220V, 30 AMP MAX DRAW.

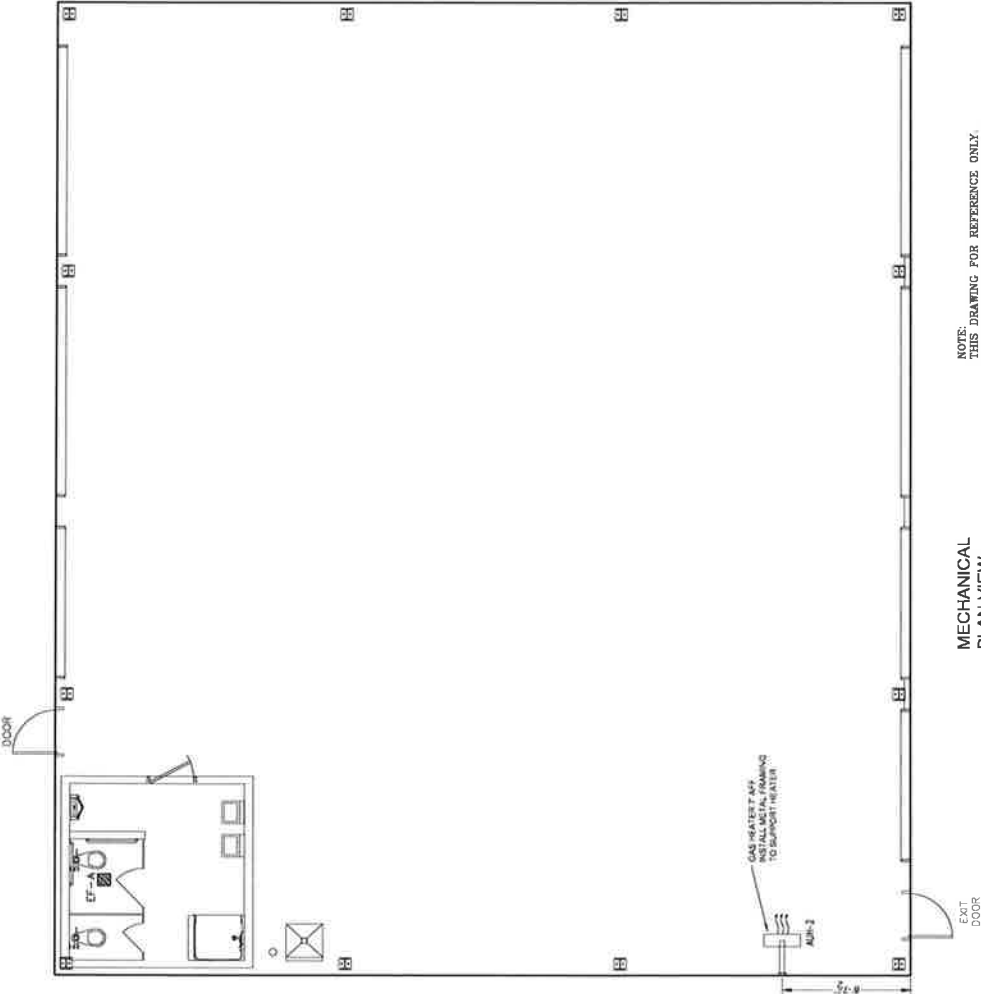

**MECHANICAL PLAN VIEW**  
 1/4" = 1'-0"

NOTES:  
 THIS DRAWING FOR REFERENCE ONLY.  
 CONTRACTOR TO SUBMIT THEIR DESIGN TO TOWN FOR REVIEW AND APPROVAL.



ELECTRICAL GENERAL NOTES

- 1. ALL WORK WITHIN THIS DIVISION SHALL COMPLY WITH ALL LOCAL BUILDING REGULATION CODES, LAWS, ORDINANCES AND ALL OTHER APPLICABLE CODES.
- 2. PRIOR TO CONSTRUCTION, THE CONTRACTOR SHALL SUBMIT A WIRING PLAN TO THE OWNER, COMPLETE WITH WIRE SIZES, CIRCUIT PANELS, ELECTRICAL RISER DIAGRAM, CONDUIT SIZES, ETC., AT THE COMPLETION OF WORK. THE DRAWINGS ON SHALL SUBMIT TO THE OWNER'S REVIEW.
- 3. DRAWINGS SHALL BE GENERAL DIAGNOSTIC AND DO NOT NECESSARILY HAVE TO INDICATE EVERY FITTING AND DETAIL.
- 4. ALL WORK SHALL BE INSTALLED SO THAT JUNCTION BOXES AND COMPONENTS SHALL BE ACCESSIBLE FOR SERVICE.
- 5. THE CONTRACTOR SHALL PROVIDE ALL NECESSARY WORK AND INSTALLED UNDER THIS DIVISION SHALL BE COVERED BY COMPLETE TWO YEAR WARRANTY.
- 6. THE CONTRACTOR SHALL BE RESPONSIBLE FOR THE PROTECTION OF ALL EXISTING WORK. ANY DAMAGE TO EXISTING WORK BY THE CONTRACTOR SHALL BE REPAIRED AT HIS OWN EXPENSE DURING THIS TWO YEAR TIME SHALL BE CORRECTED AT NO CHARGE. THIS WARRANTY SHALL INCLUDE PROVIDING ALL NECESSARY PATCHWORK. ALL PATCHWORK SHALL BE INSTALLED IN A NEAT AND WORKMANLIKE MANNER.
- 7. ALL WORK SHALL BE PERFORMED IN A NEAT AND WORKMANLIKE MANNER ACCORDING TO GENERAL ACCEPTED PRACTICES OF FIRST CLASS WORKMANSHIP.
- 8. THESE DRAWINGS INDICATE THE GENERAL ARRANGEMENT AND LOCATION OF ELECTRICAL COMPONENTS. DATA SHOWN ON THESE DRAWINGS SHALL BE USED TO VERIFY THE CORRECTNESS OF THE ELECTRICAL SYSTEM. A FINAL ELECTRICAL PLAN, CONTRACTOR SHALL REVIEW ALL CIVIL, STRUCTURAL AND MECHANICAL DRAWINGS AND SHALL ADJUST ALL WORK TO MEET THE REQUIREMENTS OF CONDITIONS INDICATED.
- 9. CONTRACTOR SHALL COORDINATE AND COORDINATE WITH OTHER TRADES TO INSURE THAT INSTALLATION OF ELECTRICAL SYSTEMS WILL NOT CAUSE OBSTRUCTION TO OTHER TRADES. THE CONTRACTOR SHALL VERIFY THAT ALL LOCATIONS SHALL BE CHECKED AND COORDINATED WITH OTHER TRADES TO AVOID CONFLICT WITH STEEL FRAMING, BEAMS, DUCTWORK, OR OTHER OBSTRUCTIONS.
- 10. WHERE WORK BY THE GENERAL CONTRACTOR RESULTS IN THE RELOCATION, REMOVAL OR RE FEEDING OF ELECTRICAL DEVICES REMAINING ON THAT CIRCUIT SYSTEMS AS REQUIRED.
- 11. PROVIDE "HACR" TYPE BREAKERS FOR ALL MECHANICAL EQUIPMENT.
- 12. IN CASES WHERE CONFLICT OCCURS BETWEEN DRAWINGS AND SPECIFICATIONS OR BETWEEN DIFFERENT TRADES, AS SPECIFIED HEREIN, THE CONTRACTOR SHALL BE RESPONSIBLE TO RESOLVE AND OBTAIN RESOLUTION OF THE CONFLICT OR OMISSION BEFORE PROCEEDING WITH THE INSTALLATION.
- 13. ALL CONDUITS CROSSING EXPANSION JOINTS SHALL HAVE EXPANSION TYPE FITTINGS. WIRING SHALL BE INSTALLED AT PROVIDE PROVISIONS AS BELOW PLATE AND SUB-PANEL LEVEL PER NEC 300.5.
- 14. ALL CONDUITS SHALL BE INSTALLED TO PROVIDE PROVISIONS AS BELOW PLATE AND SUB-PANEL LEVEL PER NEC 300.5.
- 15. A COMMON NEUTRAL SHALL BE PROVIDED FOR ALL CIRCUITS CONNECTED TO GROUND FULT CIRCUIT INTERRUPTED (G.F.C.I) TYPE NEUTRAL SHALL BE PROVIDED FOR ALL CIRCUITS CONNECTED TO GROUND FULT CIRCUIT INTERRUPTED (G.F.C.I) TYPE NEUTRAL SHALL BE PROVIDED FOR ALL CIRCUITS CONNECTED TO GROUND FULT CIRCUIT INTERRUPTED (G.F.C.I) TYPE WIRE BRANCH CIRCUITS WITH COMMON NEUTRALS REQUIRE ONLY ONE GROUND WIRE.
- 16. ALL BRANCH CIRCUIT CONDUCTORS SHALL INCLUDE A SEPARATE GREEN GROUND WIRE. SIZED PER NEC AS INDICATED CONNECTED TO EACH DEVICE AND OUTLET BOX ON THE CIRCUIT AND TO THE PANEL BOARD GROUND BUS. MULTIPLE WIRE BRANCH CIRCUITS WITH COMMON NEUTRALS REQUIRE ONLY ONE GROUND WIRE.
- 17. PROVIDE #2 AWG WITH 167 AWG GROUND WIRE FOR ALL MECHANICAL EQUIPMENT UNLESS OTHERWISE NOTED. ALL EQUIPMENT SHALL BE GROUNDED AT THE PANEL WHICH FEEDS THE EQUIPMENT.
- 18. ALL CONDUCTORS SHALL BE COPPER WITH TYPE "THW" OR "THHN" INSULATION. THE MINIMUM WIRE SIZE SHALL BE #12 MINIMUM HOMERUN SIZE SHALL BE 3M.
- 19. ALL CONDUIT SHALL BE CONCEALED IN WALLS OR ABOVE THE CEILING UNLESS OTHERWISE NOTED.
- 20. ALL CONDUIT SHALL BE INSTALLED TO PROVIDE PROVISIONS AS BELOW PLATE AND SUB-PANEL LEVEL PER NEC 300.5 SHALL BE MC TYPE (WITH GROUND) ALL CONDUIT TO AND ABOVE THE PLENUM AND CIRCUIT HOMERUNS SHALL BE ENT.
- 21. A MINIMUM OF TWO (2) 3/4" CONDUITS FOR FUTURE USE (I.E. TELEPHONE, DATA, ETC) SHALL HAVE A PULLSTRING PULLED DOWN AND SECURED AT BOTH ENDS UNLESS OTHERWISE NOTED. TWO CONDUITS ARE TO RUN FROM SERVICE ENTRANCE TO ELECTRICAL PANEL.
- 22. ALL 120V BRANCH CIRCUITS CONDUIT CONDUCTORS LONGER THAN 70'-0" SHALL BE #10 AWG AND LONGER THAN 150'-0" SHALL BE #8 AWG.
- 23. ALL 240V BRANCH CIRCUITS CONDUIT CONDUCTORS LONGER THAN 70'-0" SHALL BE #10 AWG AND LONGER THAN 150'-0" SHALL BE #8 AWG.
- 24. ALL 240V BRANCH CIRCUITS SHALL BE SUPPORTED IN COMPLIANCE WITH NEC 310.15.
- 25. ALL 240V BRANCH CIRCUITS SHALL BE SUPPORTED IN COMPLIANCE WITH NEC 310.15.
- 26. RECESSED RECESSED ACCESSORY FIXTURES SHALL BE SUPPORTED IN COMPLIANCE WITH NEC 410.1.
- 27. ALL LIGHTING AND ALL LIGHTING FIXTURES SHALL BE SUPPORTED IN COMPLIANCE WITH NEC 410.1.
- 28. ALL LIGHTING AND ALL LIGHTING FIXTURES SHALL BE SUPPORTED IN COMPLIANCE WITH NEC 410.1.
- 29. ALL SWITCHES FOR LIGHTS, FANS, ETC. INDICATED MOUNTED IN THE SAME GENERAL AREA SHALL SHARE A MULTI-GANG COVER PLATE AS REQUIRED. VERIFY ALL DOOR SWINGS WITH ARCHITECTURALLY DRAWINGS PRIOR TO ROUGH-IN.
- 30. VERIFY LOCATION OF ALL MOTORS AND EQUIPMENT BEFORE ROUGH-IN.
- 31. ALL ELECTRICAL WORK SHALL BE INSTALLED IN COMPLIANCE WITH ALL APPLICABLE ELECTRICAL CODES.
- 32. PERMANENT NAMEPLATES AS SPECIFIED OR INDICATED PRIOR TO FINAL INSPECTION.
- 33. ALL HOMERUNS SHALL BE PROTECTED 70% BREAKERS UNLESS OTHERWISE NOTED.
- 34. ALL PENETRATIONS THROUGH WALLS, FLOORS, AND CEILINGS SHALL BE FIRE STOPPED PER NEC 300.21.
- 35. COORDINATE RECEPTACLE (NEMA TYPES AND VOLTAGES) WITH EQUIPMENT.
- 36. ALL PENETRATIONS THROUGH WALLS, FLOORS, AND CEILINGS SHALL BE FIRE STOPPED PER NEC 300.21.
- 37. THE CONTRACTOR SHALL PROVIDE PROVISIONS AS BELOW PLATE AND SUB-PANEL LEVEL PER NEC 300.5.
- 38. PROVIDE DIRECTORY FOR PANELS. UPDATE EACH PANEL DIRECTORY NOTING ALL CHANGES AND ADDITIONS. CORRECTLY LABEL ALL CIRCUITS, SPARE AND SPACES. DIRECTORY SHALL BE TYPE WRITTEN, PANEL NAMES SHALL HAVE ENGRAVED NAME PLATES.



**ELECTRICAL SYMBOL LEGEND**

SYMBOL	DESCRIPTION	ON CENTER MOUNTING-HEIGHT
	CONCEALED CONDUIT IN CEILING OR WALL	18" A.F.F.
	CONCEALED CONDUIT IN FLOOR OR UNDERGROUND	18" A.F.F.
	EXPOSED CONDUIT	AS REQUIRED
	CIRCUIT HOMERUN TO PANEL EACH ARROWHEAD=1 CIRCUIT	18" A.F.F.
	NUMBER OF CONDUCTORS IN CONDUIT, EACH TICKMARK = 1 WIRE (GROUND WIRE NOT INDICATED)	18" A.F.F.
	FLEXIBLE CONDUIT OR S.O. CORD	18" A.F.F.
	CONDUIT STUBBED UP OR STUBBED DOWN	18" A.F.F.
	SURFACE MOUNTED RACEWAY	AS REQUIRED
	MULTI-OUTLET SURFACE MOUNTED RACEWAY	AS REQUIRED
	FIRE RETARDANT PLYWOOD BACKBOARD	AS REQUIRED
	WALL MOUNTED SINGLE RECEPTACLE OUTLET	18" A.F.F.
	WALL MOUNTED DUPLEX RECEPTACLE OUTLET	18" A.F.F.
	WALL MOUNTED ABOVE COUNTER DUPLEX RECEPTACLE OUTLET	18" A.F.F.
	CEILING MOUNTED DUPLEX RECEPTACLE OUTLET	18" A.F.F.
	WALL MOUNTED DUPLEX RECEPTACLE OUTLET ON ITS OWN CIRCUIT	18" A.F.F.
	WALL MOUNTED G.F.C.I. DUPLEX RECEPTACLE OUTLET	18" A.F.F.
	ABOVE COUNTER G.F.C.I. DUPLEX RECEPTACLE OUTLET	18" A.F.F.
	WALL MOUNTED QUAD RECEPTACLE OUTLET	18" A.F.F.
	WALL MOUNTED SPECIAL PURPOSE RECTANGLE OUTLET	18" A.F.F.
	JUNCTION BOX SIZE AND MOUNTING AS REQUIRED	AS REQUIRED
	WALL MOUNTED TELEPHONE OUTLET	AS REQUIRED
	WALL MOUNTED DATA/TELEPHONE OUTLET	AS REQUIRED
	CEILING MOUNTED DATA/TELEPHONE OUTLET	AS REQUIRED
	CABLE T.V. OUTLET-WALL, CEILING MOUNTED	AS REQUIRED
	120/08 VOLT PANELBOARD	AS REQUIRED
	277/480 VOLT PANELBOARD	AS REQUIRED
	WALL MOUNTED SINGLE POLE SINGLE THROW TOGGLE SWITCH	AS REQUIRED
	WALL MOUNTED 3-WAY TOGGLE SWITCH	AS REQUIRED
	WALL MOUNTED 4-WAY TOGGLE SWITCH	AS REQUIRED
	WALL MOUNTED DIMMER SWITCH (SIZE AND WATTAGE AS REQUIRED)	AS REQUIRED
	DISCONNECT SWITCH (FRAME SIZE/POLARS/RISE-IF REQUIRED) SIZE SHALL BE 30/0/0/4 UNLESS NOTED OTHERWISE	AS REQUIRED
	MOTOR STARTER SUPPLIED BY DIVISION 15	AS REQUIRED
	COMBINATION MOTOR STARTER/DISCONNECT SWITCH	AS REQUIRED
	MOTOR NUMBER INDICATES HORSEPOWER (F=FRACTIONAL)	AS REQUIRED
	2x4 FLUORESCENT LIGHT FIXTURE-NORMAL POWER, EMERGENCY POWER	AS REQUIRED
	CEILING MOUNTED LIGHT FIXTURE-NORMAL POWER, EMERGENCY POWER	AS REQUIRED
	EXIT SIGN-CEILING, WALL MOUNTED	AS REQUIRED
	EMERGENCY LIGHT FIXTURE WITH BATTERY BACKUP	AS REQUIRED
	COMBINATION EMERGENCY LIGHT FIXTURE AND EXIT SIGN WITH BATTERY BACKUP	AS REQUIRED
	POWER POLE FOR CONNECTION TO MODULAR FURNITURE, PROVIDE ALL REQUIRED CONNECTIONS FOR POWER AND DATA/COMMUNICATIONS	AS REQUIRED

**PUBLIC WORKS BUILDING**

FOR: **CITY OF HOUGHTON**

374 CABIN DRIVE  
HOUGHTON, GA 30548

**ELECTRICAL NOTES**

**E1**

**Garland & Associates Contractors, Inc.**

1020 Garland Dr. - Suite 400  
Bogart, GA 30622

www.garland-contractors.com  
Commercial - Industrial - Design/Build

Phone: 770-725-8000  
Fax: 770-725-8900

P.O. Box 370  
Bogart, GA 30622

**Garland**  
 & Associates Contractors, Inc.  
 GENERAL CONTRACTORS  
 1020 Garland Dr - Suite 400  
 Bogart, GA 30622  
 www.garland-contractors.com  
 Commercial Industrial Design/Build  
 Phone: 770-725-9900  
 Fax: 770-725-9900

NO.	DATE	SUBMITTAL/REVISION

PUBLIC WORKS  
 BUILDING  
 FOR  
 CITY OF HOSCHTON  
 524 GAIN DRIVE  
 HOSCHTON, GA 30654

---

PROJECT NO. \_\_\_\_\_  
 ELECTRICAL FLOOR PLAN

---

E2

TYPE	DESCRIPTION	AMOUNT	UNITS	NOTES
A1	19"x27" RECESSED PDL FIXTURE	1800	LUMENS	1800 LUMENS PER FIXTURE
A2	RECESSED 7'x7' LED FIXTURE	3000	LUMENS	3000 LUMENS PER FIXTURE
A3	WALL PACKLED	18	W	ON SIDE WOOD WALL, 12' AFF. ON FRONT AND REAR EXTERIOR WALLS. ON SIDE BLDG LIGHTS SHALL BE ON ONE SWITCHED CIRCUIT. ON REAR LIGHTS SHALL BE ON ONE SWITCHED CIRCUIT.

- LEGEND NOTES**
- INSTALL WALL MOUNTED 110V DUPLEX RECEPTACLE OUTLETS WHERE SHOWN, 20 AMP SERVICE
  - INSTALL 220 V, 60 AMP, 1 PHASE OUTLET
  - INSTALL EXTERIOR 220 V, 60 AMP, 1 PHASE OUTLET
  - INSTALL DUPLEX RECEPTACLE GFCI CONTROLLED OUTLET WHERE SHOWN
  - INSTALL EXTERIOR DUEL OUTLET GFCI CONTROLLED OUTLETS WHERE SHOWN, 20 AMP SERVICE
  - INSTALL 120/240 CIRCUIT PANEL ON OUTSIDE WALL OF STORAGE ROOM
  - INSTALL ALL CONDUITS FOR THE FOLLOWING:  
 - CONDUITS FOR ELECTRICAL FEED  
 - CONTRACTOR TO COORDINATE WITH CITY AND POWER COMPANY TO DETERMINE THE CLOSEST AVAILABLE POLE AND TO BE LOCATED TO MINIMIZE CONDUIT LENGTH AND TO BE INSTALLED TO THE NEAREST CONDUIT AND POWER POLE FROM THE POWER SUPPLY. THE POWER TO THE BUILDING SHALL BE 240V 1 PHASE
  - INSTALL COMBINATION EMERGENCY LIGHT FIXTURE AND EXIT SIGN WITH BATTER BACKUP

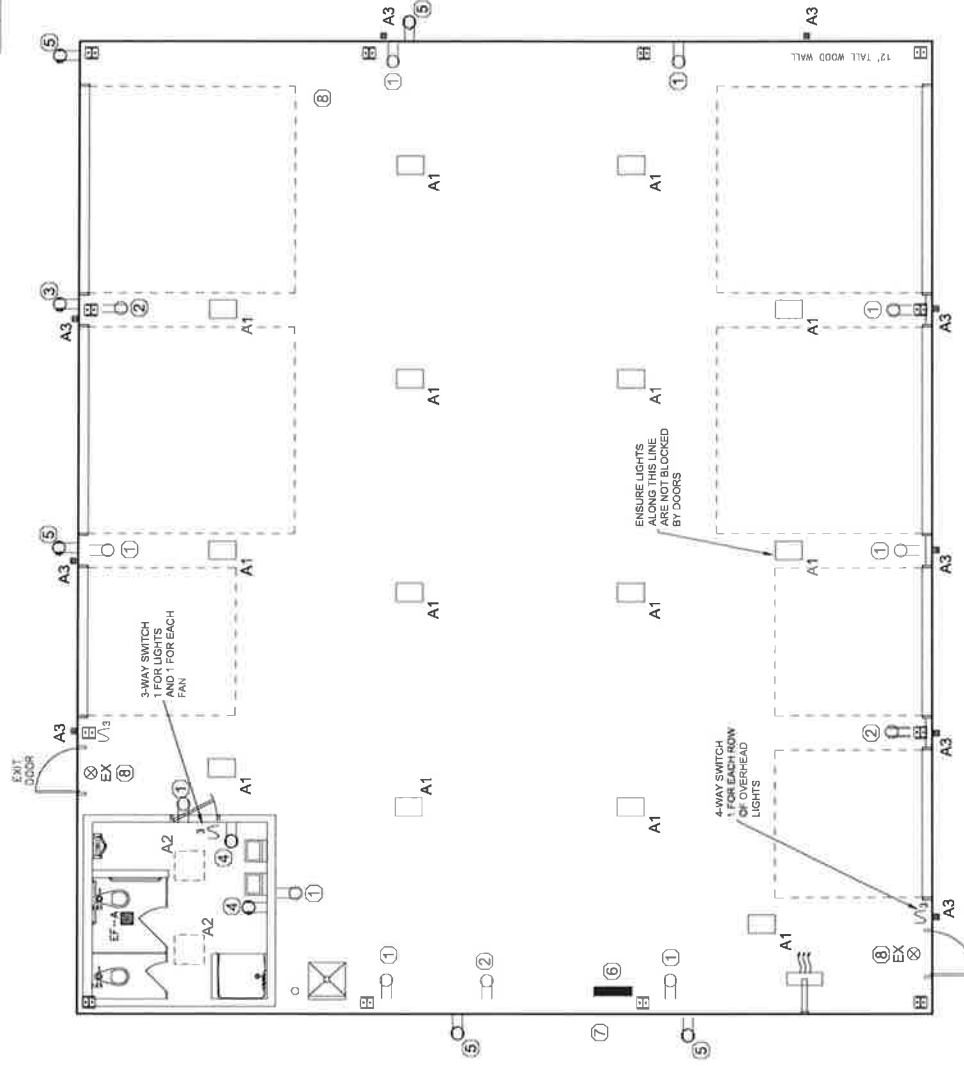

ELECTRICAL FLOOR PLAN  
 1/4" = 1'-0"

NOTE:  
 THIS DRAWING FOR REFERENCE ONLY.  
 CONTRACTOR TO SUBMIT THEIR DESIGN  
 TO TOWN FOR REVIEW AND APPROVAL.

# NEW BUSINESS

## ITEM #13

Consideration of Building Inspection  
Agreement





The following is hereby accepted as an amendment to Attachments A and B (Scope of Services and Fee Schedule) of the Professional Services Agreement between Bureau Veritas North America, Inc. and the City of Hoschton, Georgia, dated June 1, 2015 by adding the fee language as specified below. The remaining terms and conditions are unchanged. BVNA will provide the following services as-needed, as-requested to supplement and support the City's existing services.

---

## **SCOPE OF SERVICES and FEES**

### **Administration**

**Hourly Rate: \$85.00/hour – 2 hour minimum**

#### **Building Department**

A building official will be provided to oversee the work of the building department for the maintenance of department files, construction plans, applications, forms, process, consultations, code interpretation, inspection requests and review and approval of permit applications. Permit approval for residential construction includes but is not limited to building plan and application review for completeness, verification of zoning conditions, utility approval releases, and issuance of Certificates of Occupancy. Permit approval for commercial construction includes but is not limited to, application review for completeness, verification of zoning conditions, and utility approval releases. Pre-construction meetings, pre-submittal consultations, city staff meetings, research and investigation concerning projects within the city are regarded as "billable hours". Permits and Certificates of Occupancy are issued by the City. The City is the final interpretive authority.

### **Inspections and Plan Review**

**Hourly Rate: \$85.00/hour – 2 hour minimum**

#### **Residential/Commercial/Industrial Construction**

On-site residential, commercial/industrial construction inspections shall be conducted as required by the City's Building Code, Residential Code, Mechanical Code, Electrical Code, Plumbing Code, Fuel Gas Code, Fire Code and Energy Code. Special inspections as specified in chapter 17 and non-prescriptive structural inspections of the adopted International Building Code are not included and may be required as specified in the International Building Code. Inspectors will complete detailed reports in accordance with the City's procedures. Inspectors will be available for on-site consultations with the building official, contractors, homeowners or city staff as requested. Inspectors will attend all pre-construction meetings as determined by the building official.

### **Local Issuing Authority Oversight**

**Hourly Rate: \$95.00/hour – 2 hour minimum**

Land development inspections include weekly inspections of all active construction sites to determine the construction activity and installation complies with approved plans, as-built drawings, applicable codes and ordinances including tree preservation, compliance with NPDES standards for soil erosion and stormwater BMPs. Inspectors will complete and submit required annual and semi-annual reports to the EPD. Inspectors will be available for on-site consultations with the building official, contractors, homeowners or city staff as requested. Inspectors will attend all pre-construction meetings as determined by the building official. Land disturbance permits are issued by the City. The City is the final interpretive authority.



**Property Maintenance  
Code Compliance Inspections**

**Hourly Rate: \$95.00/hour – 2 hour minimum**

Property maintenance code compliance inspections shall be conducted **as-needed/asrequested** in accordance with the City's Code of Ordinances, Zoning and Sign Ordinances and the current adopted edition of the International Property Maintenance Code. Inspections include but are not limited to high grass or overgrown property, junk and debris, junk vehicles, abandoned vehicles, building dilapidation, property dilapidation, abandoned and/or nonhabitable structures. The inspector will perform routine city wide area surveys on a weekly basis. Voluntary compliance is sought through education and conversation with the violator. The inspector will document all observations and create a case file for follow-up. The property maintenance code compliance inspector reports to the building official and on occasion will require their assistance for code interpretation, site visits and direction for non-compliance notices. The City issues citations and is the final interpretive authority. The inspector will be available for court appearances as requested by the City at an additional fee.

**Out of Scope**

**Hourly Rate: \$110.00/hour – 2 hour minimum**

On occasion the City may require BVNA to perform services that are not a part of the contracted scope. These services include but are not limited to zoning administration, planning department services and public works inspections or investigation.

**Work After Hours**

**Hourly Rate: \$125.00/hour – 2 hour minimum**

Inspections or meetings after normal business hours of 8:00am – 5:00pm, Monday – Friday include but are not limited to requests made by contractors or citizens unavailable during normal operations.

**Court Appearances**

**Hourly Rate: \$150.00/hour - 1 hour minimum**

Subpoenaed or requested appearances as a witness for the city in cases related to building construction, development construction, erosion control or property maintenance code compliance.

**City of Hoschton, GA**

**Bureau Veritas North America, Inc.**

By: \_\_\_\_\_

By: Hal Chitwood

Title: \_\_\_\_\_

Title: Business Unit Manager

Signature: \_\_\_\_\_

Signature: 

Date: \_\_\_\_\_

Date: January 4, 2024